

116



# Service Manual

# Nakamichi 350

350

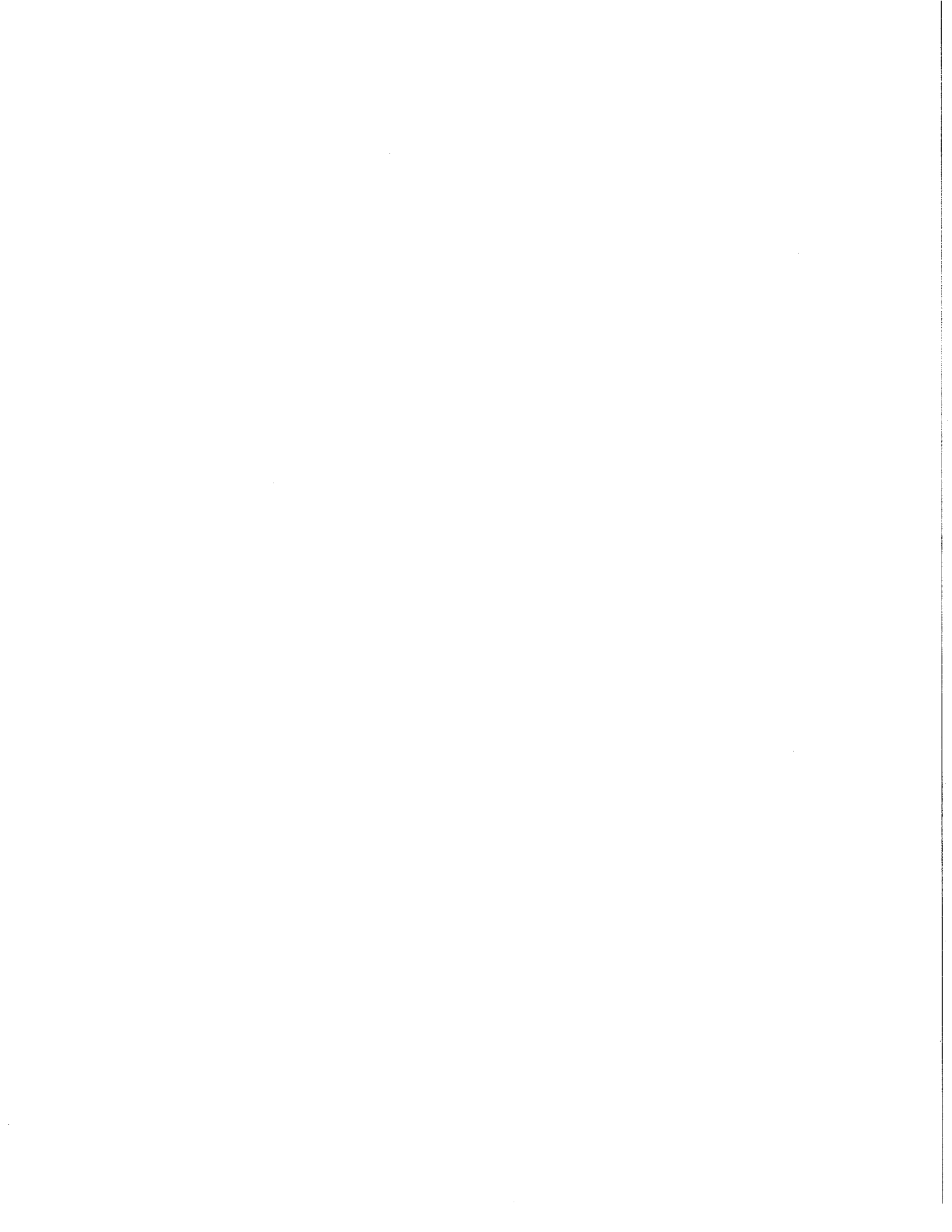



- 11. Block Diagram ..... 29
- 12. Schematic Diagram ..... 30
  - 12.1. Amplifier ..... 30
  - 12.2. Mechanism ..... 31
- 13. Specifications ..... 31
- 14. Trouble Shooting ..... 31
  - 14.1. Note ..... 31
  - 14.2. Trouble Shooting ..... 31
  - 14.3. Check Method When Parts are Replaced ..... 34

**1. GENERAL**

Nakamichi 350 control functions are shown below.  
 To maintain the optimum performance of Nakamichi 350, maintenance such as cleaning of head, capstan shaft and pressure roller, and demagnetization of heads, lubrication, etc. are required.

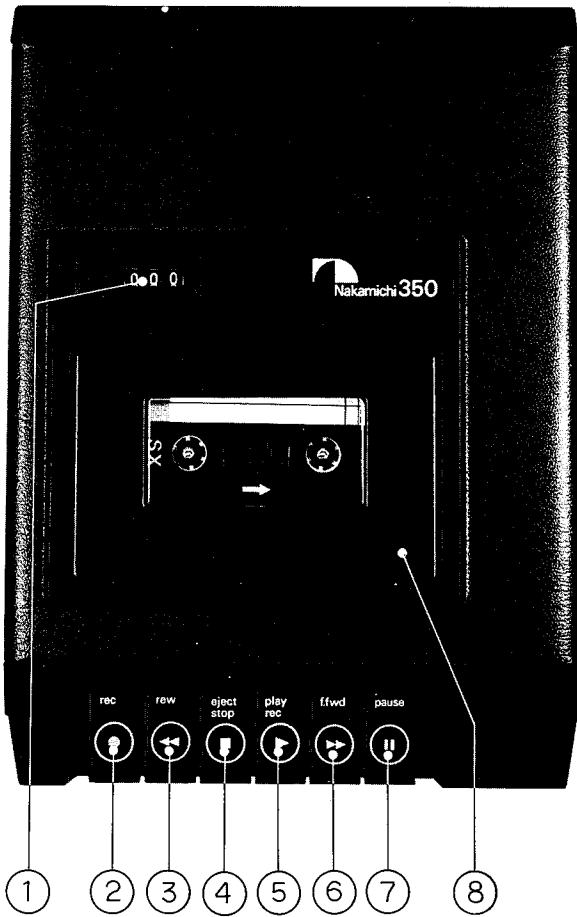

Fig. 1.1

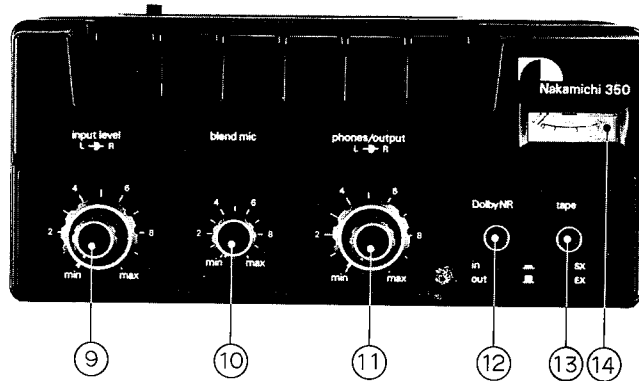

Fig. 1.2

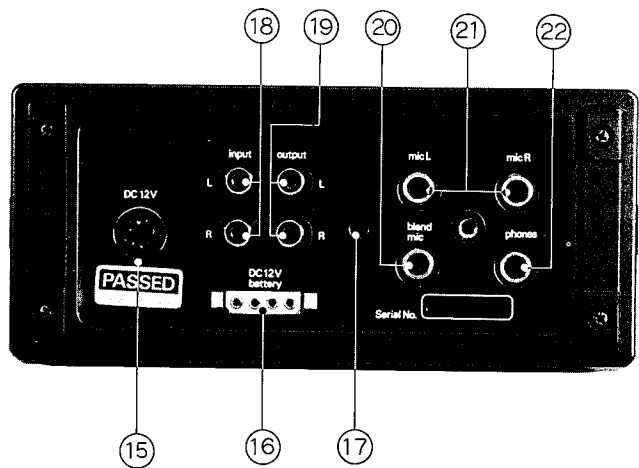

Fig. 1.3

- |                        |                                  |                               |
|------------------------|----------------------------------|-------------------------------|
| 1. Tape Counter        | 9. Input Level Controls          | 17. For Tape Speed Adjustment |
| 2. Record Button       | 10. Blend Mic. Level Controls    | 18. Line Input Jacks          |
| 3. Rewind Button       | 11. Phones/Output Level Controls | 19. Line Output Jacks         |
| 4. Stop/Eject Button   | 12. Dolby NR Switch              | 20. Blend Mic. Input          |
| 5. Play Button         | 13. Tape Selector Switch         | 21. Mic. Input Jacks          |
| 6. Fast Forward Button | 14. Peak Level Meter             | 22. Headphone Jacks           |
| 7. Pause Button        | 15. DC 12V Jack                  |                               |
| 8. Cassette Lid        | 16. 4-Pin DC 12V Car Connector   |                               |

## 2. PRINCIPLE OF OPERATION

### 2.1. Mute Signal

Fig. 2.1 shows the mute circuit and Fig. 2.2 shows the timing chart of mute signal.

When play button is depressed, +12V is supplied to mute circuit, then tape output and preamp. output lines are muted for approximately 2 seconds in order to prevent the transitional noise.

When +12V is supplied to the circuit, a differentiated positive pulse occurs at (a) through capacitor C1.

Therefore current flows into the transistor Q1 base and Q1 turns to On. Accordingly Q2 turns to On.

(b) voltage will become approximately 11.5V therefore Q3 and Q4 turn to On. When the differentiated positive pulse finished to discharge, approximately 2 seconds later Q1 turns to cutoff. Accordingly Q2, Q3 and Q4 turn to cutoff.

### 2.2. Shut-off Circuit

Fig. 2.3 shows the shut-off circuit and Fig. 2.4 and 2.5 show the timing chart.

#### (1) Tape End

At a tape end, magnet pulley assembled with tape counter stops. Accordingly reed switch On/Off stops and discharge of the capacitor C602 (synchronizing with the periodic reed switch On/Off) also stops.

Therefore C602 keeps charging and when transistor Q602 base voltage (C602 voltage) becomes positive with respect to the emitter, Q602 turns to On, and then Q603 becomes cutoff.

The voltage of Q603 collector changes from approximately 3.6V to 12V, therefore a differentiated positive pulse will be added to Q605 base through capacitor C607. Then Q605 turns to On and Q606 base current flows therefore Q606 turns to On and Q605 base current is supplied through Q606.

Namely Q605 and Q606 form a memory circuit and when trigger is added to the Q605 base, Q605 and Q606 keep On.

When Q606 turns to On, solenoid is driven by the charge of C604 (2200 $\mu$ F).

As resistance of the solenoid is approximately 12 ohms, the charge of C604 is discharged quickly, though C604 is charged through resistor R610 (330 ohms). When Q606 collector voltage becomes low by the discharge, enough Q605 base current does not flow therefore Q605 will turn to cutoff. Accordingly Q606 will turn to cutoff.

Driven solenoid will mechanically release the play, fast forward or rewind button and 12V DC for the auto shut-off circuit will be cutoff, and Nakamichi 250 will stay in stop mode.

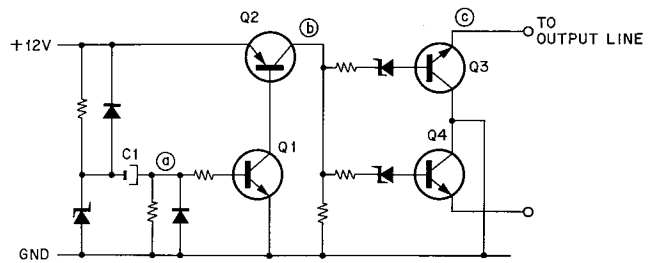

Fig. 2.1

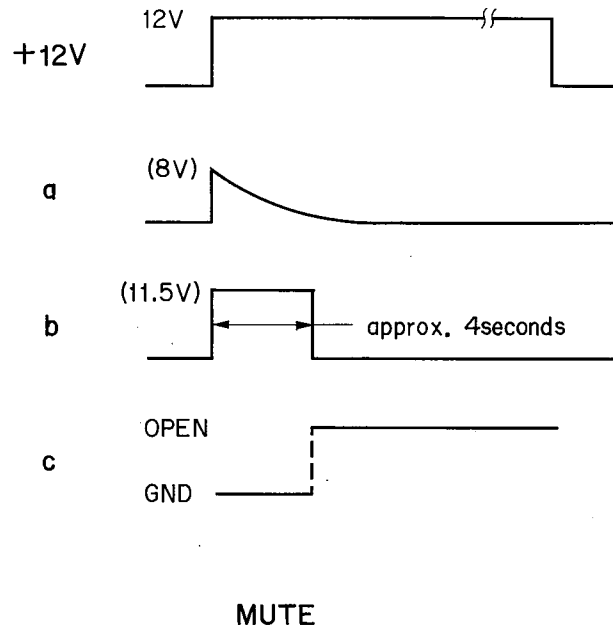

Fig. 2.2

#### (2) External Power Source Cutoff

When external power source is cut off, play or fast forward or rewind mode is released automatically. While in play, fast forward or rewind mode, 12V DC is supplied to the auto shut-off circuit, motor governor and motor. When external power source is cut off, 12V DC discharges so does Capacitor C604.

As C604 discharging time constant is great, transistor Q604 base voltage becomes positive with respect to the emitter.

And Q606 base current flows through Q604 therefore Q606 turns to On. When Q606 turns to On, solenoid is driven by the charge of C604 (2200 $\mu$ F).

Therefore play, fast forward or rewind button will be released.

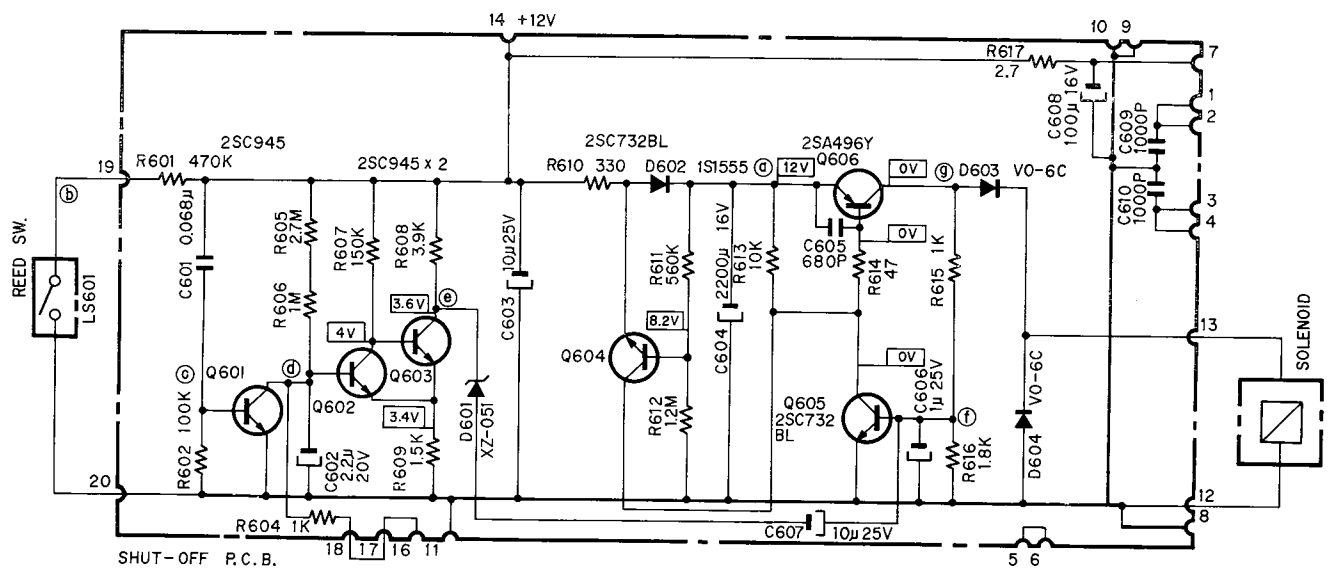
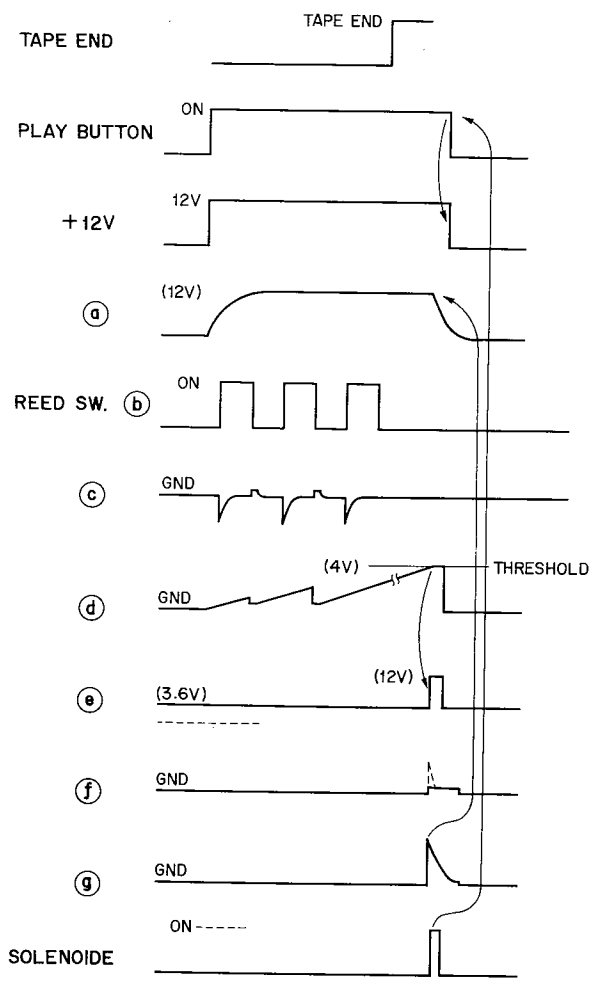

Fig. 2.3



TAPE END  
Fig. 2.4

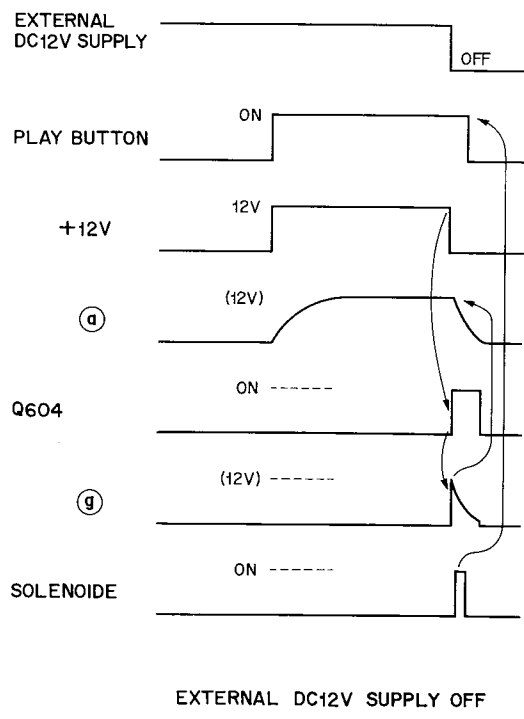

Fig. 2.5

### 2.3. Dolby-B Noise Processor Check Procedures

The Nakamichi 350 incorporates a Dolby-B noise processor IC. Fig. 2.6 shows its circuit diagram.

Table 1 shows the typical each IC-pin level measured by the following check procedures:

Note: Table 1 shows typical levels (which may slightly vary).

Check Procedures:

- (1) Remove the bias-cut jumper on the main P.C. board.
- (2) Depress the both record and pause switches.
- (3) Connect an oscillator to the line input jacks and a VTVM to the line output jacks.
- (4) Set the phones/output level controls to the maximum position, and then feed in 5KHz to obtain 0dB (580mV) output on the VTVM.
- (5) Adjust input signal level to obtain -40dB on the VTVM.
- (6) Read the each IC-pin level in Dolby NR switch In and Out modes.
- (7) Resolder the bias-cut jumper.

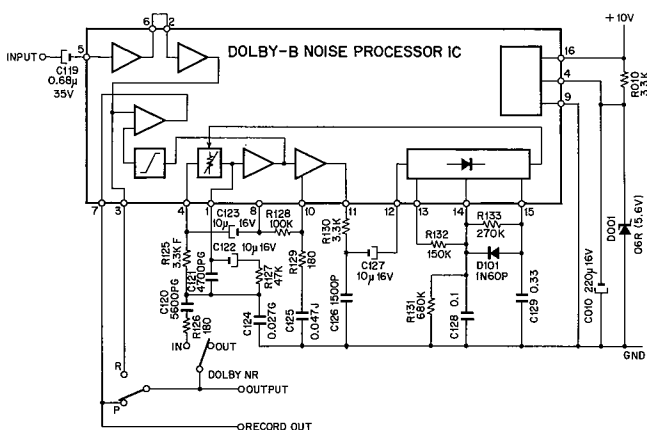

Fig. 2.6

Pin No.	Dolby NR In		Dolby NR Out	
	AC (mV)	DC (V)	AC (mV)	DC (V)
5	0.32 (0.34)	5.8	0.32 (0.34)	5.8
6,2	0.24 (0.24)	5.8	0.24 (0.24)	5.8
7	19.0 (20.5) -30dB	5.8	6.0 (6.0) -40dB	5.8
3	5.8 (6.0)	5.8	5.8 (6.0)	5.8
4	0 (0)	5.8	0 (0)	5.8
1	0.85 (0.85)	5.8	0 (0)	5.8
8	0 (0)	6.2	0 (0)	6.3
10	23.5 (25.5)	6.3	0 (0)	6.4
11	150 (185)	6.6	0 (0)	6.8
12	120 (150)	0.7	0 (0)	0.7
13	0.4 (0.5)	0.7	0 (0)	0.7
14	0.06 (0.12)	0.6	0 (0)	0.6
15	0 (0)	0.6	0 (0)	0.6
16		10V		10V
9		GND		GND

Table 1

## 3. REMOVAL PROCEDURES

### 3.1. Cabinet

Refer to Fig. 3.1 and remove F01 through F16.

### 3.2. Record/Playback Head, Erase Head and Pressure Roller

Remove the cabinet (item 3.1). Refer to Fig. 3.2 and remove F01 through F03 (pressure roller), F04 through F08 (record/playback head) and F09 through F11 (erase head).

### 3.3. Mechanism Ass'y

Remove the cabinet (3.1). Refer to Fig. 3.3 and remove F01 through F06.

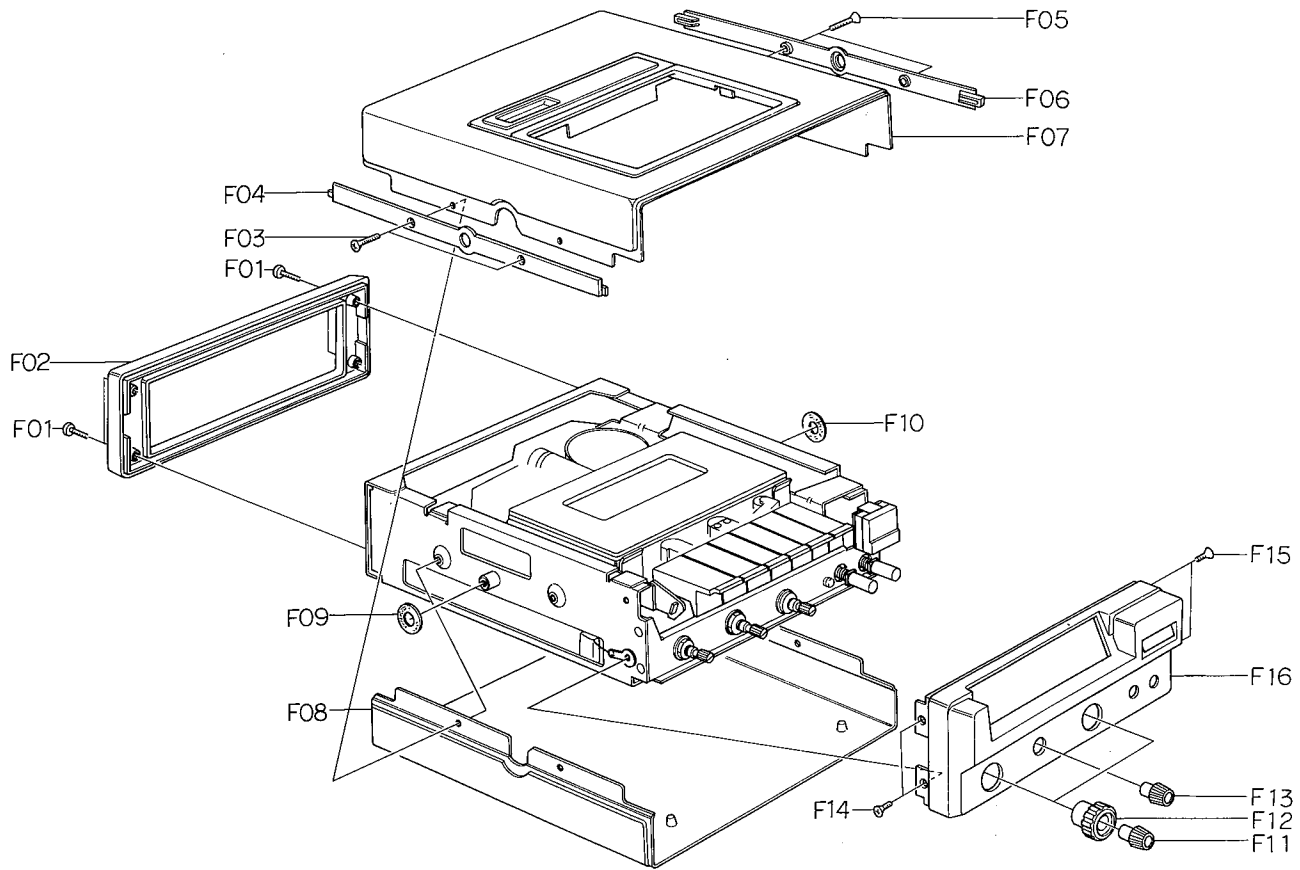

Fig. 3.1

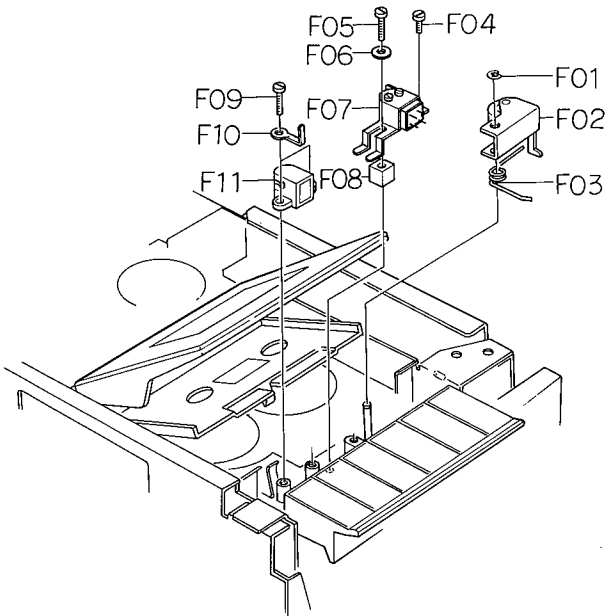

Fig. 3.2

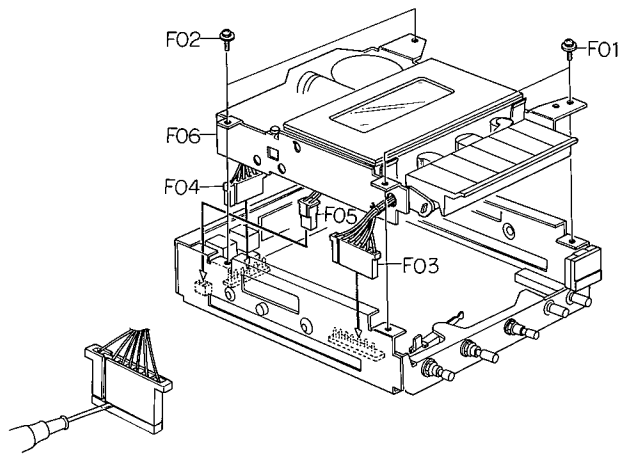

Fig. 3.3

**3.4. Input Level, Blend Mic. Level and Phones/Output Level Controls, and Switch**

Remove the mechanism ass'y (3.3). Refer to Fig. 3.4 and remove F01 through F05 and F06 through F09.

**3.5. Jacks**

Remove the cabinet (3.1). Refer to Fig. 3.5 and remove F01 through F07, F08 through F11 (4P DIN Jack), F12 through F16 (4P Pin Jack) and F17 through F23 (Mixing Mic. Jacks).

**3.6. Record Link Leaf Spring**

Remove the mechanism ass'y (3.3). Refer to Fig. 3.6 and remove F01 and F02.

**3.7. Play Switch**

Remove the mechanism ass'y (3.3). Refer to Fig. 3.7 and remove F01 through F03.

**3.8. Button Bracket Ass'y**

Remove the mechanism ass'y (3.3). Refer to Fig. 3.8 and remove F01 through F05.

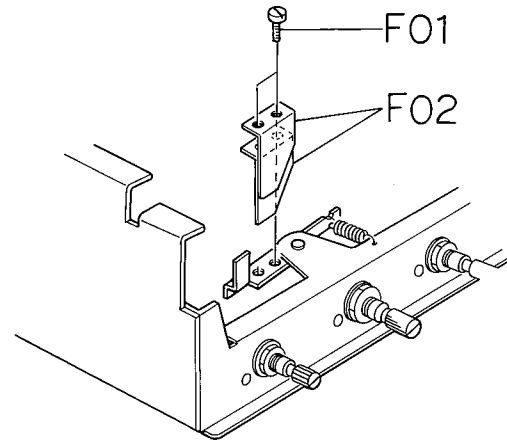

Fig. 3.6

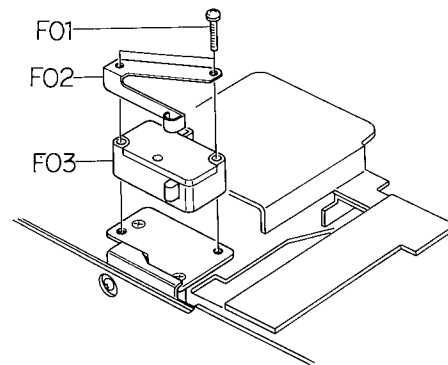

Fig. 3.7

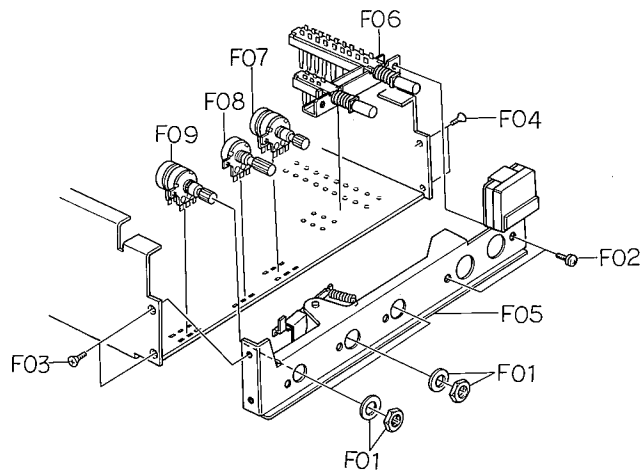

Fig. 3.4

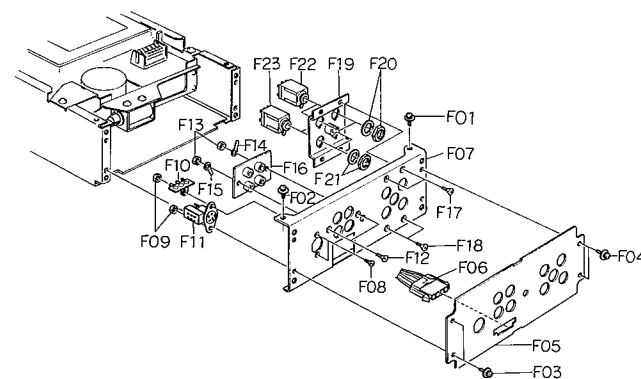

Fig. 3.5

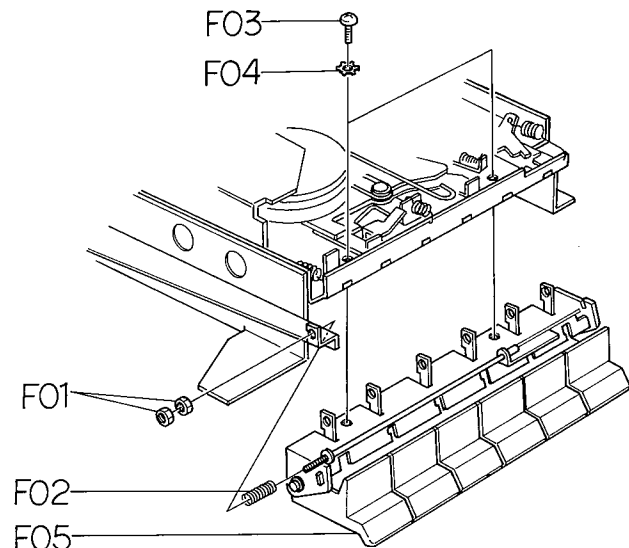

Fig. 3.8



**3.9. Solenoid**

Remove the mechanism ass'y (3.3). Refer to Fig. 3.9 and remove F01 through F03.

**3.10. Motor and Governor**

Remove the mechanism ass'y (3.3). Refer to Fig. 3.10 and remove F01 through F03 (governor) and F04 through F13 (motor).

**3.11. Flywheel and Idler Pulley**

Remove the mechanism ass'y (3.3). Refer to Fig. 3.11 and remove F01 through F06 (flywheel) and F07 through F09 (idler pulley).

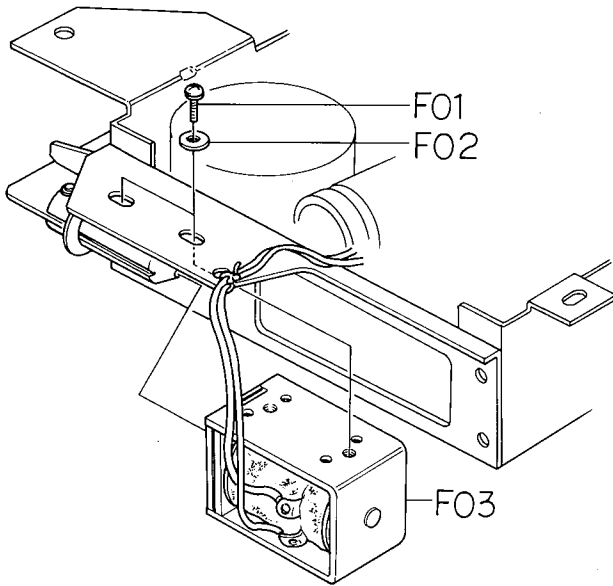

Fig. 3.9

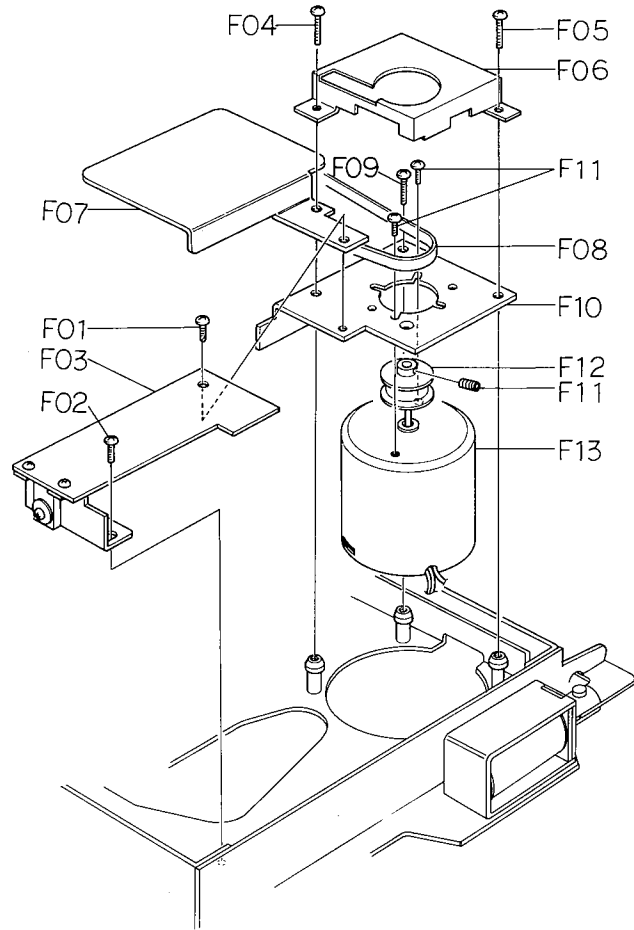

Fig. 3.10

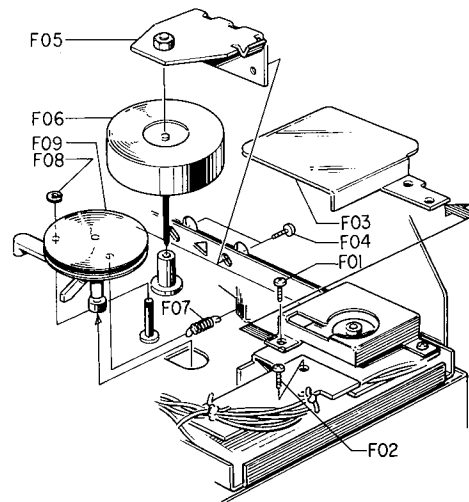

Fig. 3.11

### 3.12. Counter, Shut-off P.C.B. Ass'y and Reed Switch

Remove the mechanism ass'y (3.3). Refer to Fig. 3.12 and remove F01 through F03 (shut-off P.C.B. ass'y), F04 through F05 (counter) and F06 through F010 (reed switch).

### 3.13. Cassette Lid and Cassette Well

Remove the mechanism ass'y (3.3). Refer to Fig. 3.13 and remove F01 through F07 (cassette lid) and F08 through F10 (cassette well).

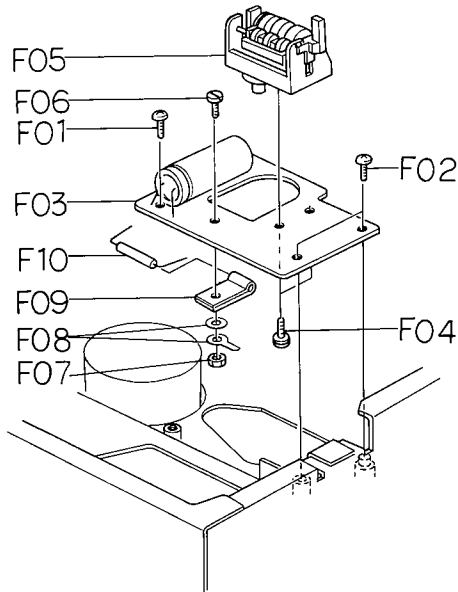

Fig. 3.12

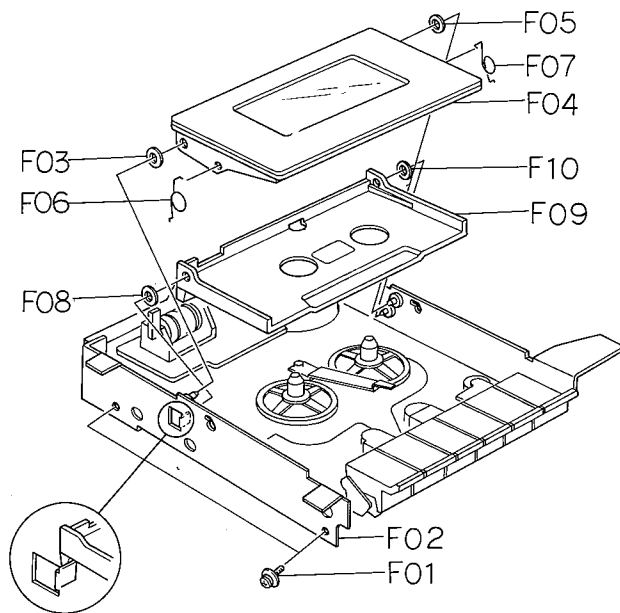

Fig. 3.13.

### 3.14. Take-up Pulley and Supply Pulley

Remove the mechanism ass'y (3.3). Refer to Fig. 3.14 and remove F01 through F04, F05 through F08 (supply pulley) and F09 through F12 (take-up pulley).

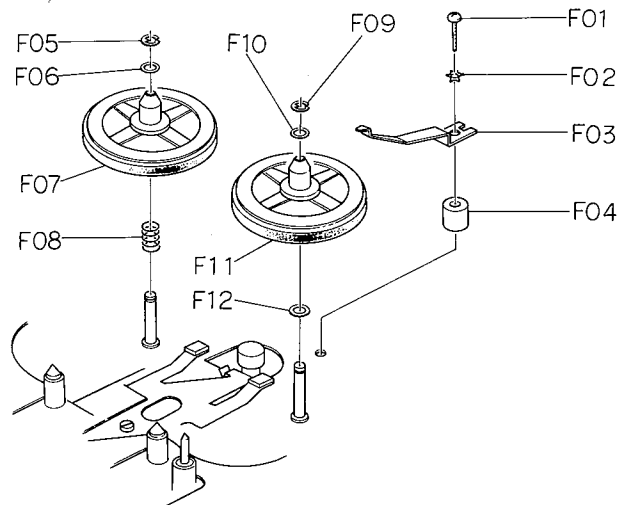

Fig. 3.14.

## 4. MEASUREMENT INSTRUMENT

- (1) Audio Generator (20Hz – 200KHz)
- (2) AC Millivolt Meter (with dB measures)
- (3) Oscilloscope (DC – 5KHz)
- (4) Distortion Meter
- (5) Speed & Wow/Flutter Meter
- (6) Frequency Counter (DC – 1MHz)
- (7) Ohm Meter
- (8) DC Volt Meter
- (9) AC Volt Meter
- (10) Tape Travelling Cassette B (part No. DA09027A)
- (11) Torque Gauge (DA09013A)
- (12) 15KHz Azimuth Tape (DA09004A)
- (13) 3KHz Speed & Wow/Flutter Tape (DA09006A)
- (14) 1KHz Track Alignment Tape (DA09007A)
- (15) 400Hz Level Tape (DA09005A)
- (16) 15KHz P.B. Frequency Response Tape (DA09002A)
- (17) 10KHz P.B. Frequency Response Tape (DA09003A)
- (18) Reference EX Tape (DA09010A)
- (19) Reference EXII Tape (DA09021A)
- (20) Reference SX Tape (DA09025A)
- (21) Track Viewer (DA09012A)
- (22) Tape Guide Adjuster (OD09001A)
- (23) Information Terminals, Model M-300  
(For positioning of record/playback head)

## 5. MECHANICAL ADJUSTMENTS

### 5.1. Take-up Torque and Rewind Torque Adjustment

To adjust torque, move torque plate as shown in the Fig. 5.1. The take-up torque should be  $45 \pm 10$ g-cm and rewind torque should be 35 to 60g-cm.

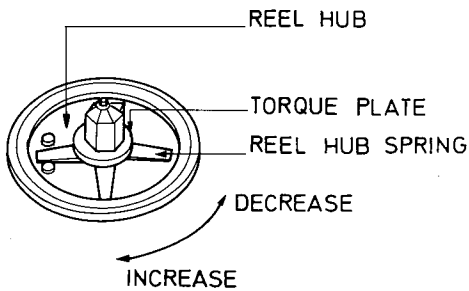

Fig. 5.1

### 5.2. Tape Speed Adjustment

- (1) Connect a frequency counter to the output jack.
- (2) Load the 3KHz Speed Wow Flutter Tape (DA-09006A) and play it back.
- (3) Adjust the tape speed adjust potentiometer. See Fig. 5.2.

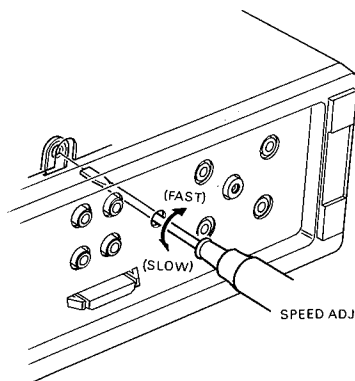

Fig. 5.2

### 5.3. Record/Playback Head Height Adjustment and Azimuth Alignment

See Fig. 5.3.

- (1) Load the Track Viwer (DA09012A) and check the positions of record/playback head. Check to insure that the L-R center of head coincides in position with the middle point between two lines (0.3mm distance) on the track viwer.
- (2) If the L-R center deviates from the middle point over 0.2mm. Correct the deviation by adding a head height spacer as illustrated in the item 9.8 (B03).
- (3) Connect a VTVM to output jacks.
- (4) Load the 1KHz Track Alignment Tape (DA09007A). Insert the Tape Guide Adjuster (OD09001A) into each hole of the tape guide beside the head. Adjust the jig for minimizing each output signal of the right and left channels.

- (5) Load the 15KHz Azimuth Tape (DA09004A). Adjust the azimuth alignment screw for maximizing each output signal of the right and left channels. After completion of the adjustment in this step, check the head height as directed in Step (4).

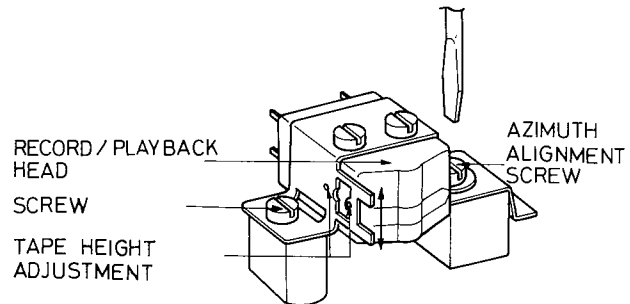

Fig. 5.3

### 5.4. Head Base Stroke Adjustment

- (1) Remove the mechanism ass'y referring to the item 3.3, mechanism ass'y removal procedure.
- (2) Adjust the height of head base stroke adjustment plate as illustrated in Fig. 5.4 (Height Adj.).
- (3) Load the "INFORMATION TERMINALS M-300" jig for positioning the record/playback head, pushing backward to eliminate the clearance between reference pin and jig.
- (4) Depress the play button and check to insure whether the positioning of the head is within the specified tolerance. If not, adjust the head base stroke adjustment plate from the bottom side at stop mode. See Fig. 5.4 (Stroke Adj.).

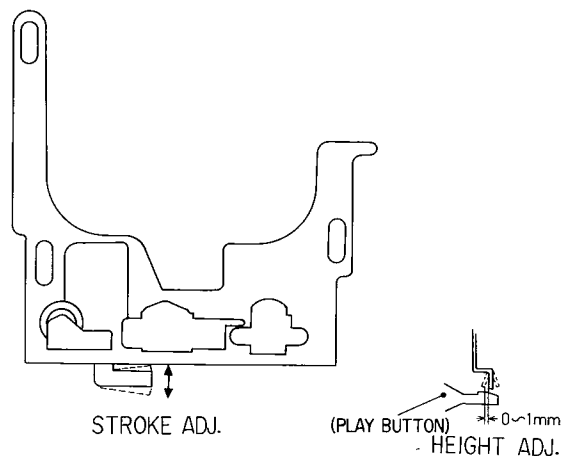

Fig. 5.4

### 5.5. Pause Timing Adjustment

This adjustment is required for avoiding the tape spill or tape skip by the inaccurate pause timing.

See Fig. 5.5.

- (1) Set to the playback mode without loading the cassette tape.
- (2) Depressing the pause button gradually, check to insure the gap between pressure roller and capstan shaft which will be approximately 0.1mm when take-up pulley stops rotation because of changing mode from playback to pause.
- (3) In case above is not sufficient, remove the record link ass'y referring to the item 3.16, record link ass'y removal procedure. And adjust the pressure roller as illustrated in the figure.

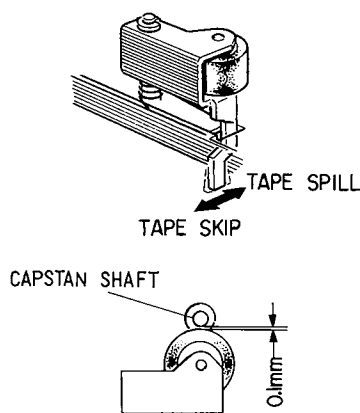

Fig. 5.5

### 5.6. Belt Travelling Adjustment

Refer to the Fig. 5.6 and item 3.10, motor and motor governor ass'y removal procedure.

- (1) Adjust the motor pulley position and check to insure whether the drive belt is travelling along the correct position and the staying at the correct position, i.e. the center part of motor pulley and the idler pulley without contacting the belt guide at the following modes:  
Playback, FF, REW, FF to Stop, REW to Stop
- (2) In case motor pulley is tilting, insert spacers into the A, B (when belt slips upward on the motor pulley) or C (when belt slips downward).

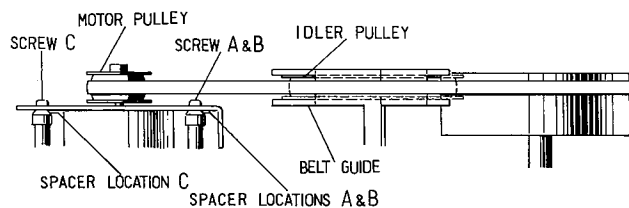

Fig. 5.6

### 5.7. Flywheel Adjustment

Refer to the Fig. 5.7 and item 3.1, cabinet removal procedure. Adjust the flywheel clearances should be 0.05 to 0.1mm. After adjustment lock the lock nut.

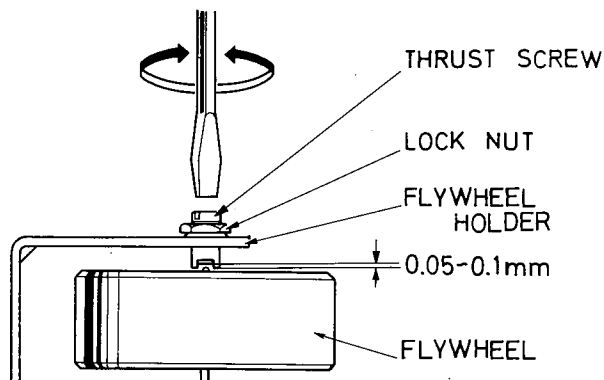

Fig. 5.7

### 5.8. Brake Timing Adjustment

Remove the cassette case referring to the item 3.13 cassette lid and cassette well removal procedure.

Refer to the Fig. 5.8.

Loosen screw A, and adjust the contact point between idler pulley and brake to meet each other when control button is depressed and mode is changed from FF to Stop, REW to Stop and Play to Stop.

Fasten screw A and check to insure the gap between idler pulley and brake is approximately within 0.2mm.

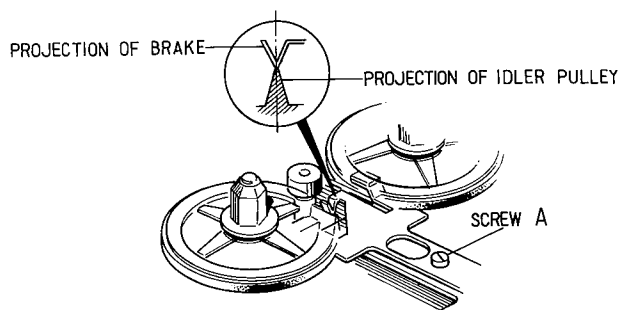
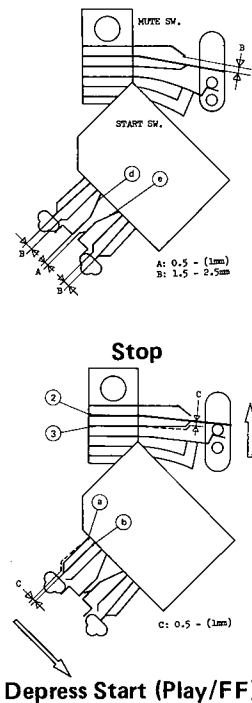

Fig. 5.8

**5.9 Mute Switch and Start Switch Adjustment**

See Fig. 5.9. Check the mute switch and start switch movement in the following modes.

- (1) Stop  
Check to insure the accuracy of gaps of A and B.
- (2) Play
  - (a) Depress Start  
Figure shows the timing when transfer 2-3 or transfer a-b opens.  
Check to insure the accuracy of gap of C.  
Broken line shows the position of transfer in stop mode.
  - (b) In the Course of Depress  
Check to insure the accuracy of gap of D.
  - (c) Depress End  
Check to insure that the transfer 4-5, 6 will open when gap E becomes more than 0.5mm.  
After play button is locked, check to insure the accuracy of gaps E and F.
- (3) Fast Forward  
Depress the fast forward button and check to insure the same start switch movement as each stage of item (2) "play" as above. While in fast forward mode, mute switch does not work.
- (4) Rewind
  - (a) Depress Start  
Figure shows the timing when transfer g-h opens.  
Check to insure the accuracy of gap G. Broken line shows the position of transfer in stop mode.



- (b) In the Course of Depress  
Check to insure the accuracy of gap H.
- (c) Depress End  
After rewind button is locked, check to insure the gap I.

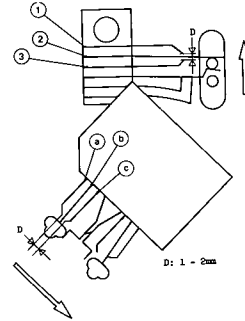

**In the Course of Depress (Play/FF)**

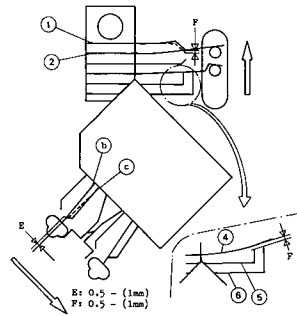

**Depress End (Play/FF)**

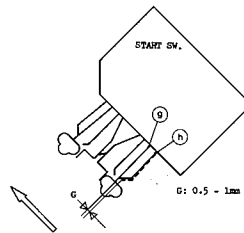

**Depress Start (REW)**

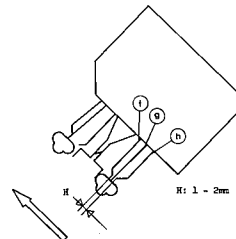

**In the Course of Depress (REW)**

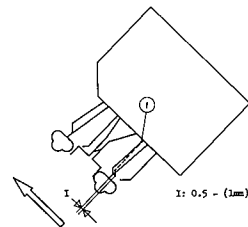

**Depress End (REW)**

Fig. 5.9

### 5.10. Solenoid Position Adjustment

- (1) Remove the mechanism ass'y referring to the item 3.3, mechanism ass'y removal procedure. See Fig. 5.10.
- (2) Loosen the screw a little and move the solenoid in the A direction.
- (3) Depress the play button.
- (4) Holding the solenoid as shown in the figure, slide the solenoid gradually by hand in the B direction.
- (5) Then play button will release. Move the solenoid approximately 0.1 to 0.3mm from the released point in the B direction. Fasten the solenoid.
- (6) Assemble the mechanism ass'y and turn the power switch on. And check to insure whether the solenoid can be released at the Play, FF, REW and Pause modes.

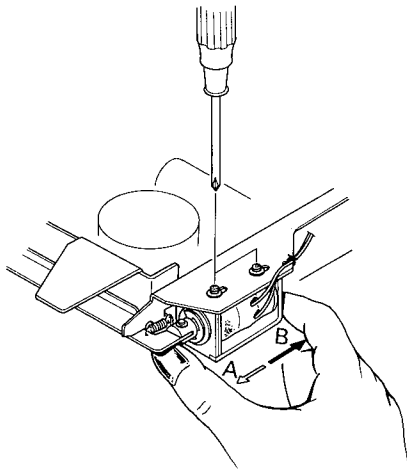

Fig. 5.10

### 5.11. Tape Travelling Adjustment

Load the Tape Travelling Cassette (DA09027A) and check the following:

- (1) After more than 2 second when depressed play button, the tolerance of the tape travelling fluctuation on the record/playback head shall not be more than 0.1mm.
- (2) Tape is contact with head sufficiently.
- (3) Tape waving is small (on the head and pressure roller).

If tape travelling is not good, re-adjustment of 5.1. "Take-up Torque and Rewind Torque Adjustment", 5.3. "Reocrd/Playback Head Height Adjustment", 5.4. "Head Base Stroke Adjustment" and others will be required.

### 5.12. Lubrication

After 500 hours of use apply a few drops of light machine oil (LAUNA No. 40) to the pressure roller shaft.

Note: If the lubrication oil is applied also to the capstan shaft and other drive mechanisms, clean it off with an alcohol-dipped cloth.

When flywheel or flywheel holder is replaced apply a few drops of grease to the flywheel holder.

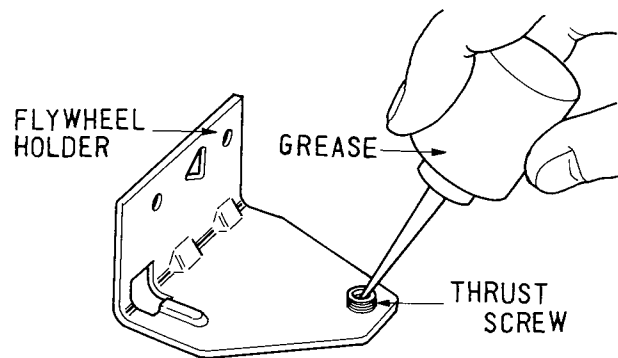
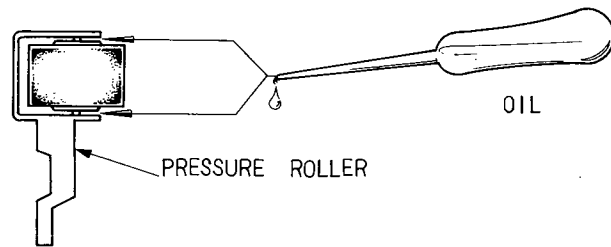

7. PARTS LOCATION FOR ELECTRICAL ADJUSTMENT

STEP	ITEM	SIGNAL SOURCE	OUTPUT CONNECTION	MODE	ADJUSTMENT	REMARKS
15	Eraseure	1KHz to INPUT Jacks	1KHz Band Pass Filter and VTVM to OUTPUT Jacks	Record & Playback Tape SW, SX Dolby NR Sw.-OUT		<ol style="list-style-type: none"> <li>1. Erase the tape with bulk eraser.</li> <li>2. Adjust input level controls to obtain 0dB (580mV) on the VTVM, record the signals on the reference tape.</li> <li>3. Rewind the Tape then close input level controls.</li> <li>4. Record and play it back, then measure the difference between 2 and 3.</li> </ol>
16	Signal to Noise Ratio	400Hz to INPUT Jacks	VTVM and Distortion Meter to OUTPUT Jacks	Record & Playback Tape SW, SX Dolby NR Sw.-In		<ol style="list-style-type: none"> <li>1. Feed in 400Hz, record and play it back.</li> <li>2. Adjust input level controls to obtain 3% total harmonic distortion in playback mode.</li> <li>3. Close the input level controls then record.</li> <li>4. After rewind, play back and check the output level difference between 2 and 3.</li> </ol> <p>Note: The filter of CCITT curve shall be used in the measurement.</p>
17	Total Harmonic Distortion	400Hz to INPUT Jacks	Distortion Meter to OUTPUT Jacks	Record & Playback Tape SW, SX Dolby NR Sw.-Out		<ol style="list-style-type: none"> <li>1. Adjust input level controls to obtain 0dB (580mV) on the VTVM.</li> <li>2. Record and play it back.</li> <li>3. Read the distortion meter.</li> </ol>
18	Wow/Flutter	3KHz Speed & Wow/Flutter Tape (DA09006A)	Wow/Flutter Meter to OUTPUT Jacks	Playback		Playback and read the wow/flutter meter.

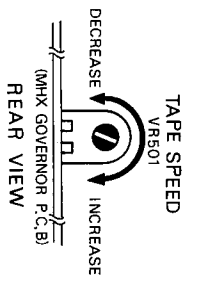
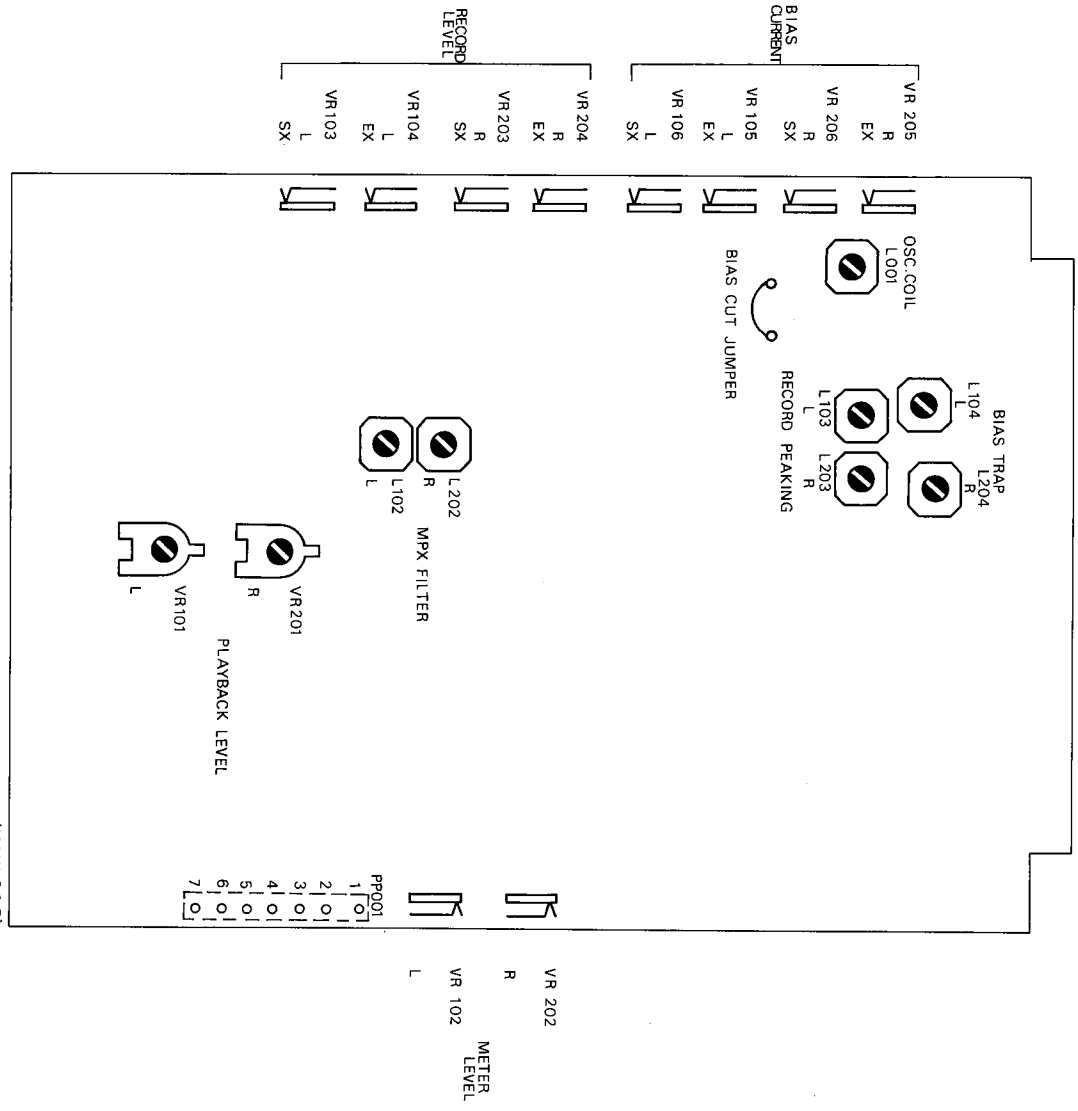

Fig. 7

## 6. ELECTRICAL ADJUSTMENTS AND MEASUREMENTS

Refer to the item 7 "Parts Location for Electrical Adjustment", wherein semi-fixed volume and bias-cut jumper are shown.

STEP	ITEM	SIGNAL SOURCE	OUTPUT CONNECTION	MODE	ADJUST-MENT	REMARKS
1	Tape Speed	3KHz Speed & Wow/Flutter Tape (DA09006A)	Frequency Counter to OUTPUT Jacks	Playback	MHX Governor P.C.B. VR501	Adjust VR501 to obtain 3KHz $\pm 1.5\%$ .
2	Meter Level	400Hz to INPUT Jacks	VTVM to OUTPUT Jacks	Record Pause	Main P.C.B. VR102, VR202	1. Set phones/output level controls to the maximum position. 2. Adjust input level controls to obtain 580mV (0dB) on the VTVM. 3. Adjust VR102 (VR202) to obtain 0dB on the level meter. Note: Connect a signal source with one channel (L or R) at one time.
3	MPX Filter	19KHz $\pm 100$ Hz to INPUT Jacks	VTVM to OUTPUT Jacks	Record Pause	Main P.C.B. L102, L202	Adjust the coil L102 (L202) to obtain minimum reading on the VTVM.
4	Tape Guide Alignment	1KHz Track Alignment Tape (DA09007A)	VTVM to OUTPUT Jacks	Playback Tape Sw.-SX Dolby NR Sw.-OUT	Tape Guide of Record/ Playback Head	Adjust the azimuth alignment screw to obtain maximum reading of both L and R channels on the VTVM. See Item 5.3 "Record/Playback Head Height Adjustment and Azimuth Alignment".
5	Playback Head Azimuth Alignment	15KHz Azimuth Tape (DA09004A)	VTVM to OUTPUT Jacks	Same as above	Azimuth Alignment Screw	Adjust tape guide with Tape Guide Adjuster (OD09001A) to obtain minimum reading of both L and R channels on the VTVM. See Item 5.3 "Record/Playback Head Height Adjustment and Azimuth Alignment".
6	Playback Level	400Hz Level Tape (DA09005A)	VTVM to OUTPUT Jacks	Same as above	Main P.C.B. VR101, VR201	Adjust the VR101 (VR201) to obtain 580mV on the VTVM.
7	Playback Frequency Response	400Hz Level Tape (DA09005A) 10KHz P.B. Frequency Response Tape (DA09003A) 15KHz P.B. Frequency Response Tape (DA09002A)	VTVM to OUTPUT Jacks	Same as above		1. Load the 400Hz level tape and play it back. Adjust the phones/output level controls to certain level (example 0dB). 2. Load the 10KHz, 15KHz P.B. frequency response tapes and adjust the playback head azimuth to give maximum levels on the VTVM with each tape. Check to insure the playback levels against 400Hz level tape are as follow. 10KHz and 15KHz tapes -20dB $\pm 3$ dB -20dB $\pm 3$ dB Azimuth Alignment".
8	Bias Oscillation Frequency		Frequency Counter to Connector PP001-Pin No. 2 on the Main P.C.B.	Record Pause	Main P.C.B. L001	Adjust the coil to obtain 105KHz on the frequency counter.
9	Record Amplifier Equalizer	400Hz (-20dB) and 15KHz (-20dB) to INPUT Jacks	VTVM to Connector PP001-Pin No. 6 (L), 3 (R) on the Main P.C.B.	Record Pause Tape Sw.-SX Dolby NR Sw.-OUT	Main P.C.B. L103, L203	1. Remove the bias-cut jumper from the dip side of the main P.C.B. 2. Feed in 15KHz (-20dB) and adjust the coils to obtain approximately 14dB high level with respect to the level at 400Hz (-20dB) input. 3. Resolder bias-cut jumper.
10	Bias Trap	Remove Input Signals	Same as above	Same as above	Main P.C.B. L104, L204	Adjust the coils to obtain maximum reading on the VTVM.
11	Record Level Calibration	400Hz to INPUT Jacks	VTVM to OUTPUT Jacks	Record & Playback Tape Sw.-EX/SX Dolby NR Sw.-OUT	Main P.C.B. VR104, 103 VR204, 203	1. Record the signals on the Reference EX11 Tape (DA09021A) or Reference SX Tape (DA09025A) and play it back. 2. Repeating 1 as above, adjust VR104 (VR204) (for EX11) and VR103 (VR203) (for SX) to obtain 580mV (0dB) on the VTVM (with phones/output level controls maximum position).
12	Recording Bias Current	400Hz to INPUT Jacks and 40Hz to 15KHz (-20dB) to INPUT Jacks	VTVM and Distortion Meter to OUTPUT Jacks	Record & Playback Tape Sw.-EX/SX Dolby NR Sw.-OUT	Main P.C.B. VR105, 106 VR205, 206	1. Feed in 400Hz and adjust input level controls to obtain 580mV (0dB) on the VTVM (with phones/output level controls maximum position). 2. Record the signals on the reference EX11 tape (DA09021A) or SX tape (DA09025A). 3. Repeating 2 as above, play back the tape and adjust VR105 (VR205) (for EX11) or VR106 (VR206) (for SX) to obtain maximum reading on the VTVM. 4. Conduct step 11 "Record Level Calibration". 5. Feed in 10KHz (-20dB), record and play it back. Adjust VR105 (VR205) (for EX11) or VR106 (VR206) (for SX) to obtain approximately -20dB on the VTVM. Then feed in 15KHz (-20dB), record and play it back. Adjust recording peaking coils L103 (L203) to obtain approximately -20dB on the VTVM. 6. Conduct step 11 "Record Level Calibration". 7. Feed in 400Hz and adjust the input level controls to obtain 0dB on the VTVM, the record and play it back and check whether the Total Harmonic Distortion is less than 2%. Feed in 40Hz to 15KHz (-20dB), record and play it back, and check to insure whether the output level is within -20dB $\pm 3$ dB.
13	Crosstalk	1KHz to INPUT Jacks	1KHz Band Pass Filter and VTVM to OUTPUT Jacks	Record & Playback Tape Sw.-SX Dolby NR Sw.-OUT		1. Erase the tape with bulk eraser. 2. Adjust input level controls to obtain 0dB (580mV) on the VTVM, record the signals on the reference tape. 3. Turn the cassette tape the other way round and play it back. 4. Measure the difference between 2 and 3.
14	Channel Separation	1KHz to INPUT Jacks	Same as above	Same as above		1. Erase the tape with bulk eraser. 2. Adjust Lch (Rich) input level controls to obtain 0dB (580mV) on the VTVM, and close Rich (Lch) input level control. 3. Record and play it back, then measure the Rich (Lch) level.



8. MOUNTING DIAGRAM AND PARTS LIST

Note: Mounting diagram shows a dip side view of the printed circuit board.

8.1. Shut-off P.C.B. Ass'y

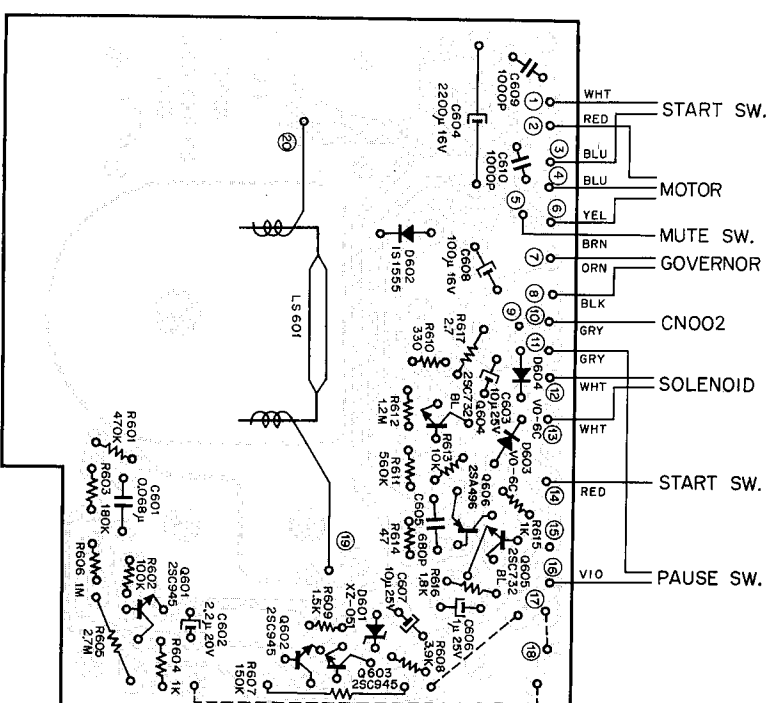

Fig. 8.1

8.2. MHX Governor P.C.B. Ass'y (B)

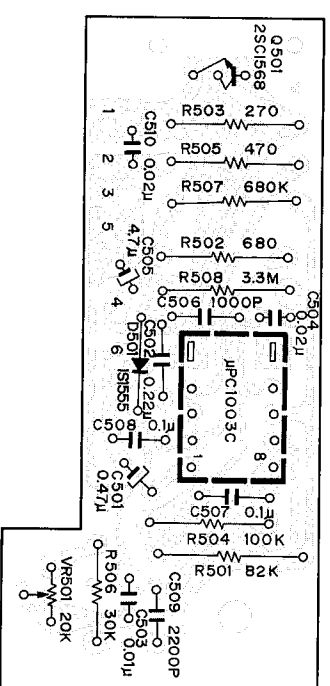

Fig. 8.2

Schematic Ref. No.	Part No.	Description
	<b>BA03767A</b>	<b>Shut-off P.C.B. Ass'y</b>
0601, 602	0B07643A 0B01872A	Shut-off P.C.B. Transistor
0603, 605	0B06005A 0B01695A	Transistor
0606	0B06048A	Zener Diode
D601	0B01909A	Silicon Diode
D602	0B01501A	Silicon Diode
D603, 604	0B05700A	Carbon Resistor
F601	0B01920A	Carbon Resistor
F602	0B05669A	Carbon Resistor
F603	0B01781A	Carbon Resistor
F604, 615	0B05753A	Carbon Resistor
F605	0B05593A	Carbon Resistor
F606	0B05664A	Carbon Resistor
F607	0B05593A	Carbon Resistor
F608	0B05664A	Carbon Resistor
F609	0B05505A	Carbon Resistor
F610	0B01789A	Carbon Resistor
F611	0B05665A	Carbon Resistor
F612	0B05537A	Carbon Resistor
F613	0B01833A	Carbon Resistor
F614	0B05569A	Carbon Resistor
F616	0B01830A	Carbon Resistor
F617	0B05836A	Carbon Resistor
C601	0B05586A	Mylar Capacitor
C602	0B05598A	Tantalum Capacitor
C603, 607	0B01674A	Electrolytic Capacitor
C604	0B01406A	Electrolytic Capacitor
C605	0T04027A	2200µ 16V Ceramic Capacitor
C606	0B01173A	680P 50V Electrolytic Capacitor
C608	0B01400A	1µ 25V Electrolytic Capacitor
C609, 610	0T04025A	100µ 16V Ceramic Capacitor
LS601	0B03803A	1000P 50V Ceramic Capacitor
	0C03763A	Reed Switch
	CA03247A	Reed Switch Holder
	0E00130A	Tape Counter Ass'y
	0E00149A	Earth Lug 2.6mm
	0E00176A	Washer 2.3mm
	0E00185A	Nut Hex M2
	0E00612A	Screw M2x6 Cylinder Head
	0B08204A	Screw M3x6 Philips Pan Head (2A)
		MHX Governor P.C.B. Ass'y (B)



Schematic Ref. No.	Part No.	Description	Schematic Ref. No.	Part No.	Description	
R014	OB05767A	Metal Film Resistor 13K CRA ¼ G	R142,242 PP002 PP001 PP003	-- MISCELLANEOUS --		
R015	OB05511A	Carbon Resistor 820 ELR ¼ J		OB07668B	Main P.C.B.	
R143,243 147,247	OB01833A	Carbon Resistor 10K ELR ¼ J		OB07036A	Record Switch	
R144,244	OB05766A	Metal Film Resistor 82K CRA ¼ G		OB01781A	Carbon Resistor 1K ELR ¼ J	
R145,245	OB01920A	Carbon Resistor 100K ELR ¼ J		OB08169A	6P Pin-Plug	
R146,246	OB05544A	Metal Film Resistor 390K CRA ¼ G		OB08218A	7P Pin-Plug	
C014	OB01400A	Electrolytic Capacitor 100µ 16V		OB08167A	2P Pin-Header	
C015	OB05861A	Electrolytic Capacitor 6.8µ 16V M (MS)				
C016	OB05864A	Electrolytic Capacitor 47µ 16V M (MS)				
C133,233	OB01405A	Electrolytic Capacitor 1µ 16V				
C134,234	OB04062A	Mylar Capacitor 0.022µ 50V K				
-- BIAS OSC. --						
Q007,008	OB01338A	Transistor 2SC735 (Y)				
L001	OB03932A	OSC. Coil				
VR105,205 106,206	OB01848A	Semi-Fixed Volume 100K				
R021	OB05865A	Metal Film Resistor 4.7 1W				
R022,023	OB05696A	Carbon Resistor 6.8 R 50 J				
R024,025	OB05608A	Carbon Resistor 220 ELR ¼ J				
R026,027	OB05505A	Carbon Resistor 1.5K ELR ¼ J				
R028	OB05746A	Carbon Resistor 1 ELR ¼ J				
C018,020	OB05684A	Mylar Capacitor 0.039µ 50V K				
C019	OB04062A	Mylar Capacitor 0.022µ 50V K				
C021	OB01400A	Electrolytic Capacitor 100µ 16V				
C022	OB01904A	Mylar Capacitor 0.082µ 50V K				
C023	OB01603A	Mylar Capacitor 0.1µ 50V K				
C147,247	OB05599A	Ceramic Capacitor 150P 50V M				
-- HEADPHONE --						
Q104,204	OB06005A	Transistor 2SC732 (BL)				
Q105,205	OB01338A	Transistor 2SC735 (Y)				
Q106,206	OB01426A	Transistor 2SA562 (Y)				
D102,202	OB01702A	Sillicon Varistor KB269				
R135,235	OB05538A	Carbon Resistor 27K ELR ¼ J				
R136,236	OB05593A	Carbon Resistor 150K ELR ¼ J				
R137,237	OB01781A	Carbon Resistor 1K ELR ¼ J				
R138,238	OB01879A	Carbon Resistor 33K ELR ¼ J				
R139,239 140,240	OB05545A	Carbon Resistor 18 ELR ¼ J				
R141,241	OB05619A	Carbon Resistor 22 R50 ½ W				
C130,230	OB01412A	Electrolytic Capacitor 10µ 16V				
C131,231	OB01405A	Electrolytic Capacitor 1µ 16V				
C132,232	OB01398A	Electrolytic Capacitor 220µ 16V				
-- MUTE --						
Q005	OB06013A	Transistor 2SA733				
Q006,109 209	OB06005A	Transistor 2SC732 (BL)				
D006,008	OB01909A	Sillicon Diode 1S1555				
D007,105 205	OB06004A	Zener Diode 08S				
R016	OB05566A	Carbon Resistor 2.2K ELR ¼ J				
R017	OB01877A	Carbon Resistor 6.8K ELR ¼ J				
R018	OB05596A	Carbon Resistor 220K ELR ¼ J				
R019	OB05568A	Carbon Resistor 120K ELR ¼ J				
R134,234	OB05608A	Carbon Resistor 220 ELR ¼ J				
R148,248	OB01857A	Carbon Resistor 1K R ¼ J				
C024	OB01412A	Electrolytic Capacitor 10µ 16V				
-- DC SUPPLY --						
Q003	OB01823A	Transistor 2SD235				
Q004	OB06013A	Transistor 2SA733				
D002,003	OB01909A	Sillicon Diode 1S1555				
D005	OB06073A	Zener Diode 10S				
R011	OB05562A	Carbon Resistor 47K ELR ¼ J				
R012	OB05505A	Carbon Resistor 1.5K ELR ¼ J				
C011,012	OB01392A	Electrolytic Capacitor 470µ 16V				
C013	OB01397A	Electrolytic Capacitor 1000µ 16V				

## 9. MECHANISM ASS'Y AND PARTS LIST

## 9.1. Synthesis (A01)

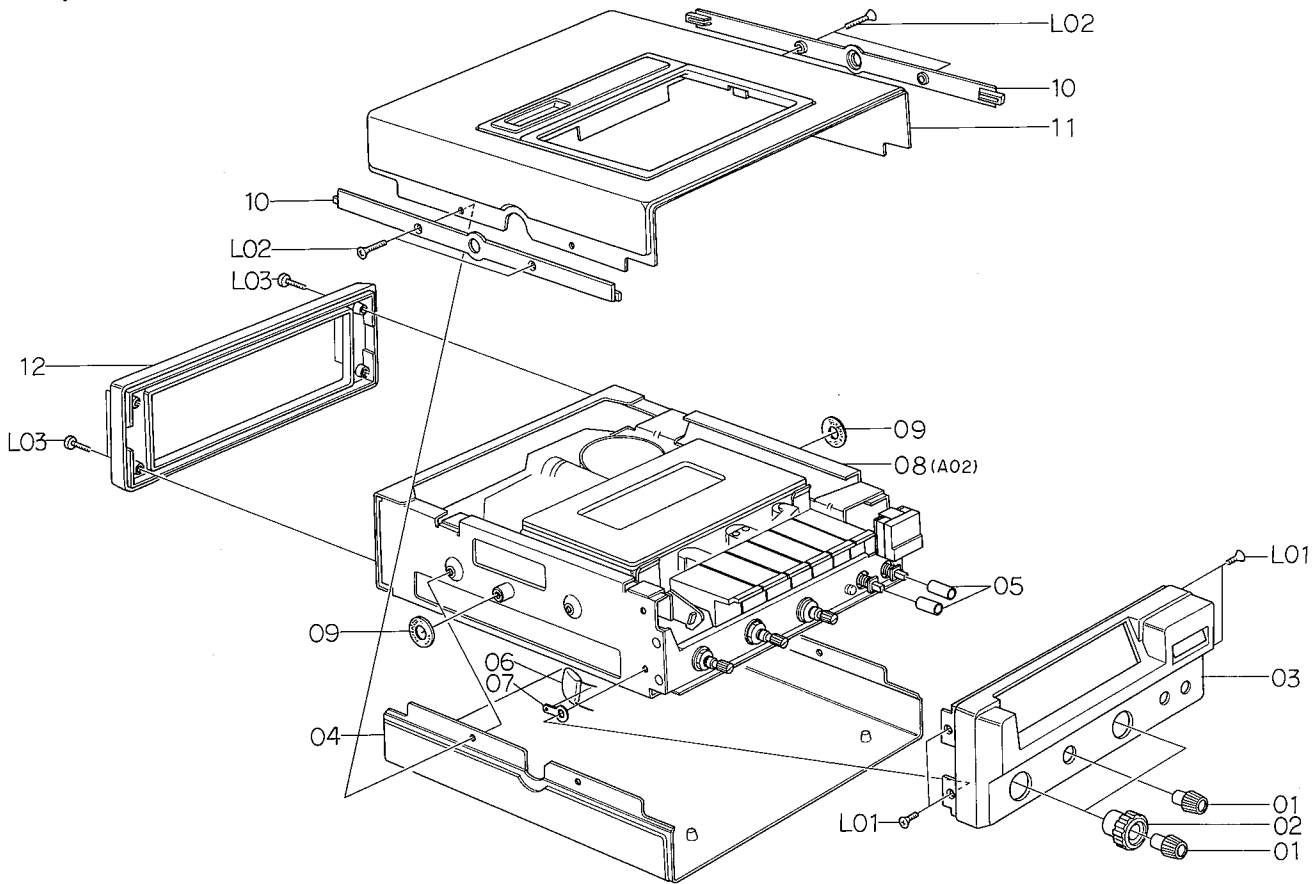

Fig. 9.1

Schematic Ref. No.	Part No.	Description	Q'ty	Schematic Ref. No.	Part No.	Description	Q'ty
<b>A01</b>		<b>Synthesis</b>		<b>A02</b>	<b>JA03092A</b>	<b>Chassis Ass'y</b>	<b>1</b>
01	0H03430A	VR Knob (C)	3	01	0B08211A	Meter 350	1
02	HA03649A	VR Knob (A) Ass'y	2	02	0J03467A	Meter Cushion	1
03	HA03644A	Front Cabinet Ass'y	1	03	0J03434A	Meter Holder	1
04	HA03648A	Bottom Case Ass'y	1	04	0M03669A	ADJ. Label 350	1
05	0H03426A	Push Switch Button	2	05	JA03086A	Side Chassis R Ass'y	1
06	0B01602A	Mylar Capacitor 0.33 $\mu$ 50V K	1	06	JA03094A	Front Chassis Ass'y 350	1
07	0E00037A	Earth Lug B-5	1	07	JA03085A	Side Chassis L Ass'y	1
08	JA03092A	Chassis Ass'y	1	08	0M03669A	Meter Label 350	1
09	0J03476A	Soft Washer	2	09	JA03095A	Rear Chassis Ass'y 350	1
10	0H03423A	Side Cover	2	10	CA03294A	Mechanism Ass'y 350	1
11	HA03650A	Upper Case Ass'y 350	1	11	0M03563A	Record Plate	1
12	0A03259A	Rear Cabinet	1	12	0M03564A	REW. Plate	1
L01	0E00505A	Screw M3x6 Philips Countersunk Head	4	13	0M03565A	Stop Plate	1
L02	0E00599A	Screw M3x10 Philips Oval Countersunk Head (Bronze)	4	14	0M03566A	Play Plate	1
L03	0E00703A	Screw M3x14 Philips Pan Head (Bronze)	4	15	0M03567A	F.F. Plate	1
				16	0M03568A	Pause Plate	1
				L01	0E00612A	Screw M3x6 Philips Pan Head (2A)	1
				L02	0E00602A	Screw M3x4 Philips Countersunk Head	4
				L03	0E00606A	Screw M3x6 Philips Pan Head (3A)	10

9.2. Chassis Ass'y (A02)

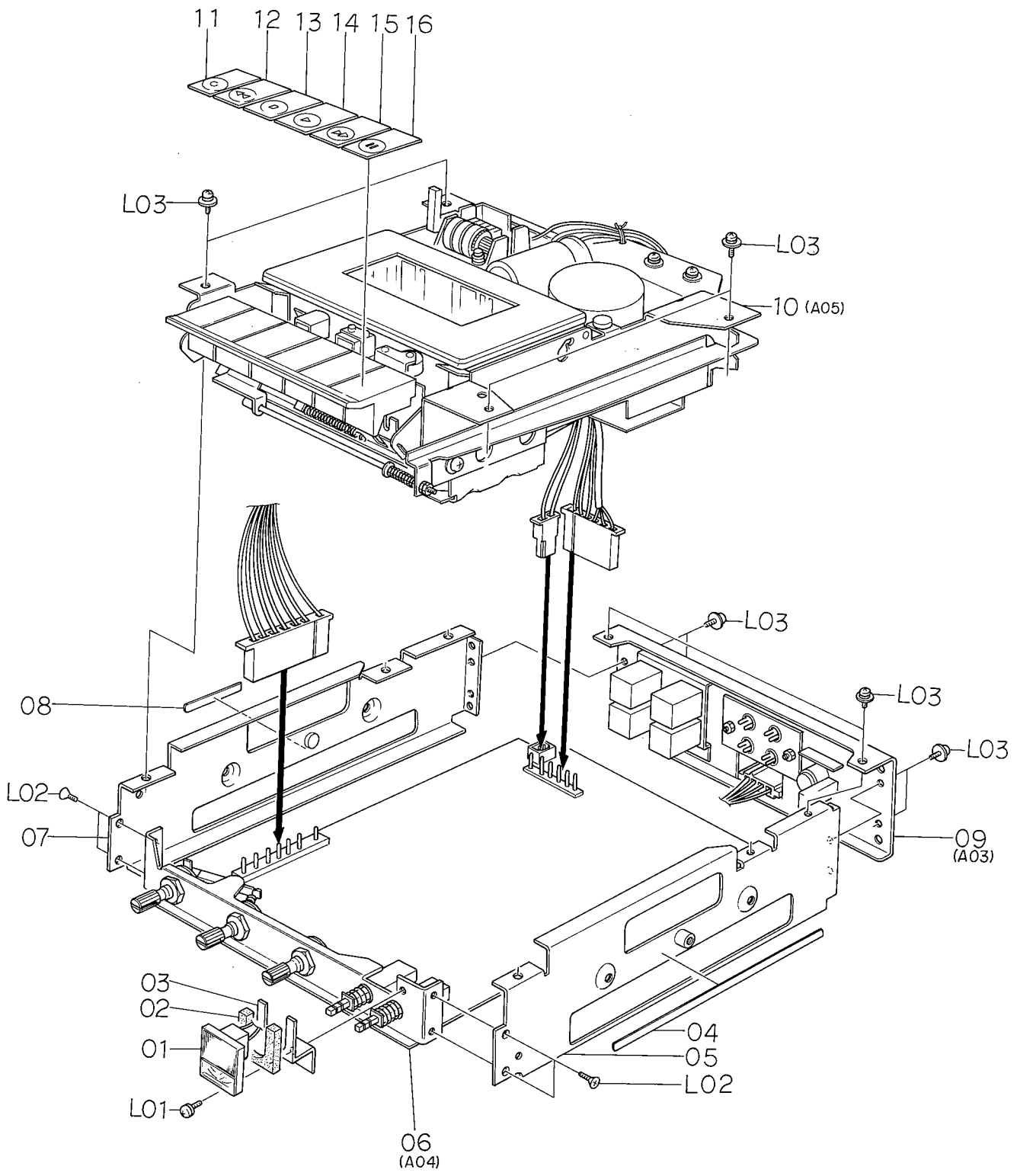

Fig. 9.2

9.3. Rear Chassis Ass'y 350 (A03)

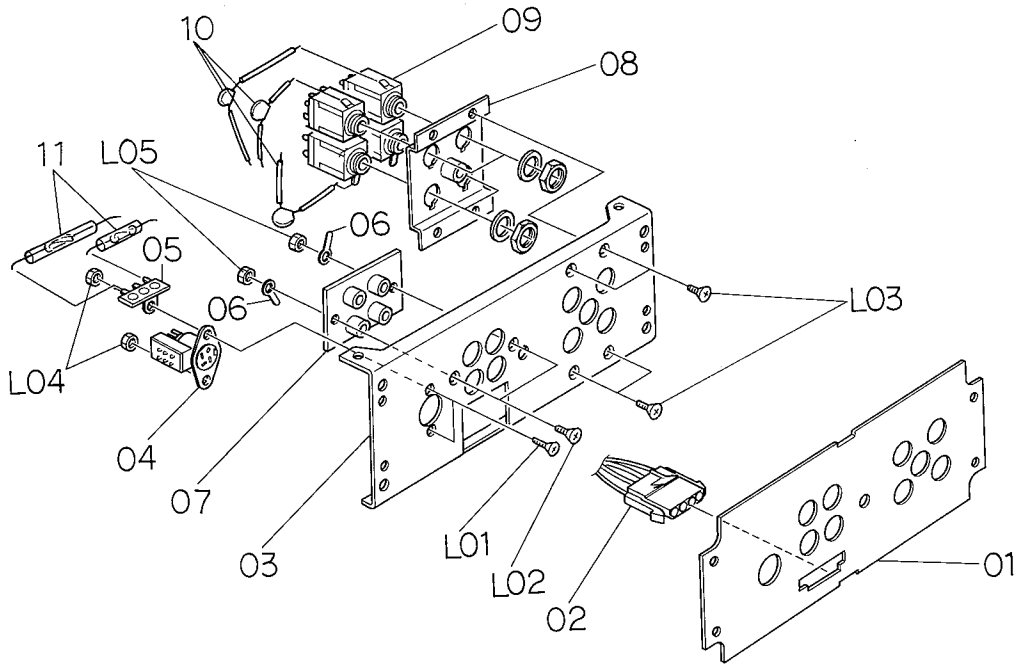

Fig. 9.3

9.4. Front Chassis Ass'y 350 (A04)

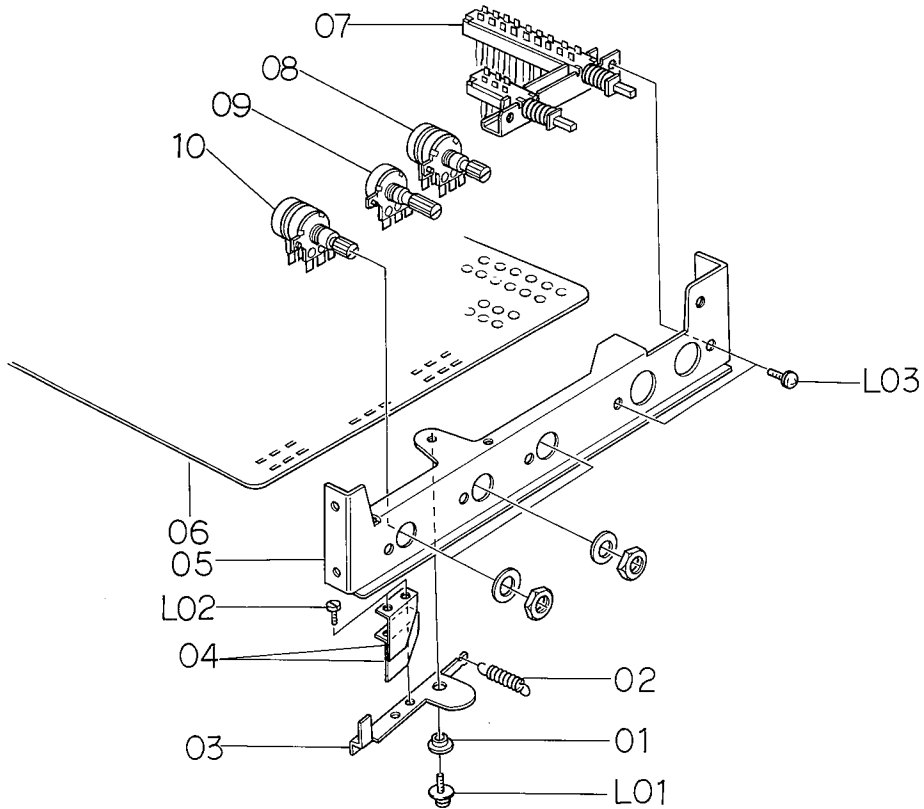

Fig. 9.4

Schematic Ref. No.	Part No.	Description	Q'ty
<b>A03</b>	<b>JA03095A</b>	<b>Rear Chassis Ass'y 350</b>	<b>1</b>
01	OJ03431A	Rear Plate	1
02	OB08224A	4P Mini-Connector Jack	1
03	OJ03427A	Rear Chassis 350	1
04	OB08135A	4P DIN Jack	1
05	OB04042A	1L 2P Lug Terminal	1
06	OE00037A	Earth Lug B-5	2
07	OB08171A	4P Pin Jack	1
08	JA03098A	Jack Holder Sub Ass'y	1
09	OB03881A	Mixing Mic. Jack	4
10	OJ04027A	Ceramic Capacitor 680P 50V M	3
11	OB05562A	Carbon Resistor 47K ELR¼ J	2
L01	OE00184A	Screw M2.6x6 Philips Countersunk Head	2
L02	OE00518A	Screw M3x8 Philips Counter- sunk Head	2
L03	OE00533A	Screw M3x5 Philips Counter- sunk Head	4
L04	OE00681A	Nut Hex. M2.6	2
L05	OE00552A	Nut Hex. M3	2
<b>A04</b>	<b>JA03094A</b>	<b>Front Chassis Ass'y 350</b>	<b>1</b>
01	OC03955A	Solenoid Arm Center	1
02	OC03957A	Solenoid Arm Spring	1
03	OJ03474A	Record Link Plate	1
04	OJ03475B	Record Link Leaf Spring	2
05	OJ03430B	Front Chassis 350	1
06	BA03768A	Main P.C.B. Ass'y	1
07	OB07120A	Push Switch 350	1
08	OB07119A	Volume 10K (A) x 2	1
09	OB07117A	Volume 50K (A)	1
10	OB07118A	Volume 50K (A) x 2	1
L01	OE00606A	Screw M3x6 Philips Pan Head (3A)	1
L02	OE00166A	Screw M2x4 Cylinder Head	2
L03	OE00612A	Screw M3x6 Philips Pan Head (2A)	2

9.5. Mechanism Ass'y 350

9.5.1. Mechanism Ass'y 350 (A05-1)

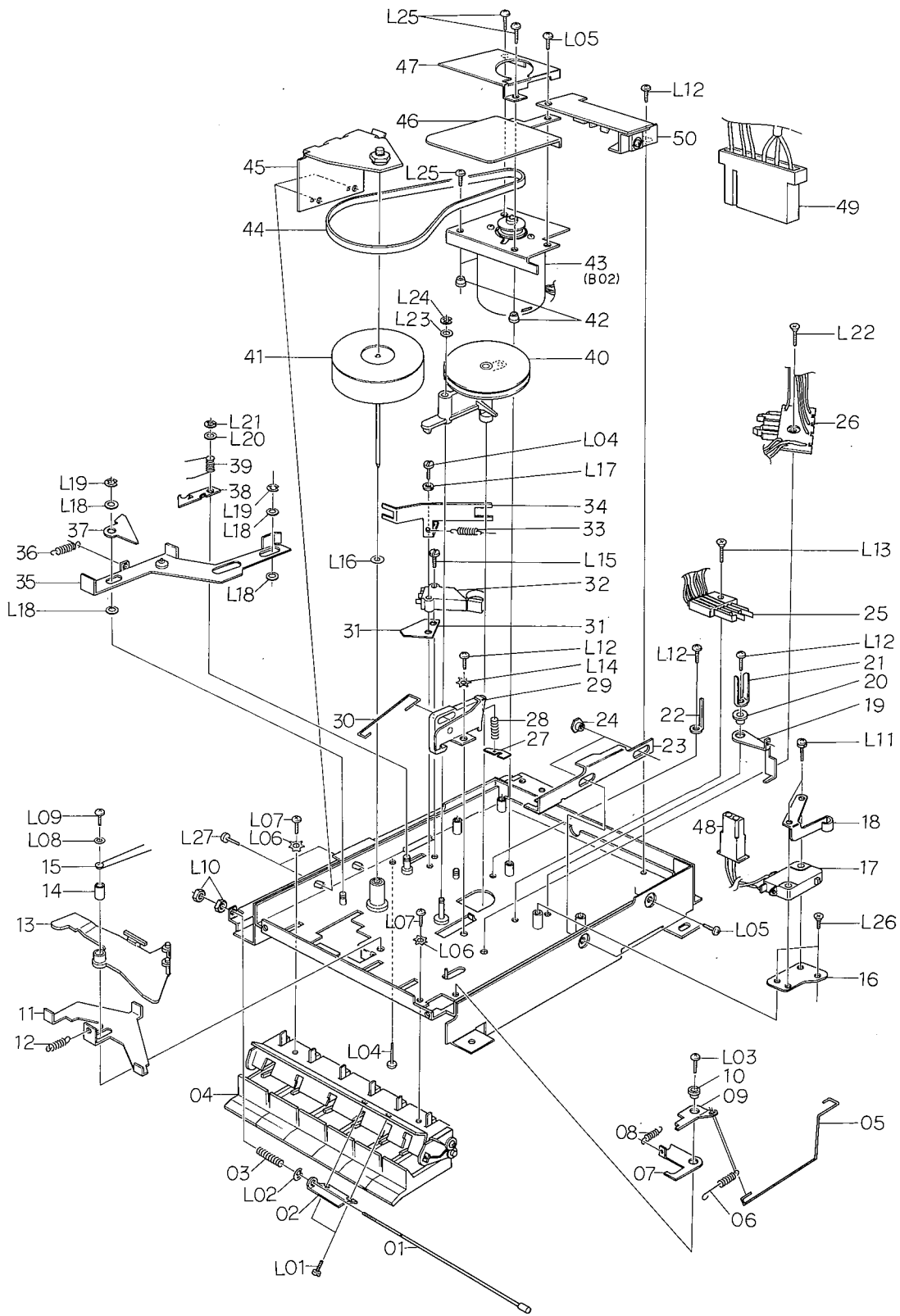

Fig. 9.5



Schematic Ref. No.	Part No.	Description	Q'ty	Schematic Ref. No.	Part No.	Description	Q'ty
A05-1	CA03294A	Mechanism Ass'y 350	1	L22	0E00223A	Screw M2x10 Philips Countersunk Head	1
01	CA03291A	Eject Linkage Ass'y	1	L23	0E00254A	Washer 3.1 mm Plastics	1
02	0C03960A	Linkage Joint	1	L24	0E00222A	E Ring 2 mm	1
03	0C03958A	Linkage Spring	1	L25	0E00220A	Screw M2.6x8 Philips Pan Head	3
04	CA03230A	Button Bracket Ass'y (B)	1	L26	0E00076A	Screw M2x4 Philips Counter-sunk Head	2
05	0C03704A	Record Sensor Linkage (B)	1	L27	0E00226A	Screw M2.6x4 Philips Pan Head	2
06	0C03791A	Record Lock Spring (B)	1				
07	0C03773C	Base Cam 1	1				
08	0C03774A	Base Cam Spring	1				
09	0C03652C	Record Lock (B)	1				
10	0C03775C	Base Cam Shaft	1				
11	0C03647B	See-Saw Arm	1				
12	0C03649A	See-Saw Arm Spring	1				
13	0C03646A	FRP Lever (B)	1				
14	0C03648A	See-Saw Arm Pipe	1				
15	0C03650B	Lever Spring	1				
16	0C03962A	Play Switch Plate	1				
17	0B07115A	Play Switch	1				
18	0C03964A	Play Switch Actuator	1				
19	0C03909A	Record Sensor (B)	1				
20	0C03546A	Record Lock Shaft	1				
21	0B03067A	Bind Holder	1				
22	0C03591A	Cord Holder	1				
23	0C03961A	Play Switch Slide Plate	1				
24	0C03963A	Slide Center	1				
25	CA03141A	Mute Switch Ass'y	1				
26	CA03231A	Start Switch (C) Ass'y	1				
27	0C03644A	Spring Stopper	1				
28	0C03552B	Eject Spring	1				
29	CA03118A	Eject Arm Ass'y	1				
30	0C03553A	Eject Linkage Wire	1				
31	0C03800A	Pause Switch Mylar	1				
32	0C03743A	Pause Switch	1				
33	0C03718A	Earth Spring (C)	1				
34	0C03799E	Belt Guide	1				
35	0C03744B	Pause Slide Plate	1				
36	0C03748A	Slide Plate Spring	1				
37	0C03746C	Pause Bar	1				
38	0C03084A	Pause Lock Lever	1				
39	0C03747A	Lock Lever Spring	1				
40	CA03150A	Idler Pulley Ass'y	1				
41	CA03225A	Flywheel (B) Ass'y	1				
42	0C03805B	Stud Collar (B)	3				
43	CA03253B	MHX Motor Ass'y (B)	1				
44	0C03668A	Driving Belt	1				
45	CA03226A	Flywheel Holder (C) Ass'y	1				
46	0C03859A	Shield Plate	1				
47	0C03814D	Motor Shield	1				
48	0B08223A	2P Mini-Connector Plug	1				
49	0B08203A	6P Mini-Connector Plug	1				
50	0B08204A	MHX Governor Ass'y (B)	1				
L01	0E00166A	Screw M2x4 Cylinder Head	2				
L02	0E00042A	E Ring 1.5 mm	1				
L03	0E00231A	Screw M2.6x8 Philips Pan Head (FT)	1				
L04	0E00218A	Screw M2x10 Cylinder Head	2				
L05	0E00219A	Screw M2.6x5 Philips Pan Head	3				
L06	0E00172A	Washer 3 mm Toothed Lock	2				
L07	0E00509A	Screw M3x6 Philips Pan Head	2				
L08	0E00142A	Washer 2.6 mm	1				
L09	0E00229A	Screw M2.6x10 Philips Pan Head	1				
L10	0E00176A	Nut Hex. M2	2				
L11	0E00704A	Screw M3x14 Philips Pan Head (2A)	2				
L12	0E00228A	Screw M2.6x6 Philips Pan Head (FT)	4				
L13	0E00008A	Screw M2.6x8 Philips Countersunk Head	1				
L14	0E00233A	Washer 2.6 mm Toothed Lock	1				
L15	0E00004A	Screw M2x8 Cylinder Head	1				
L16	0C03174A	Washer 2.1 mm Plastics	1				
L17	0E00025A	Washer 2 mm Spring	1				
L18	0E00031A	Washer 4 mm	4				
L19	0E00181A	E Ring 3 mm	2				
L20	0E00253A	Washer 3.3 mm Steel	1				
L21	0E00222A	E Ring 2 mm	1				

9.5.2. Mechanism Ass'y 350 (A05-2)

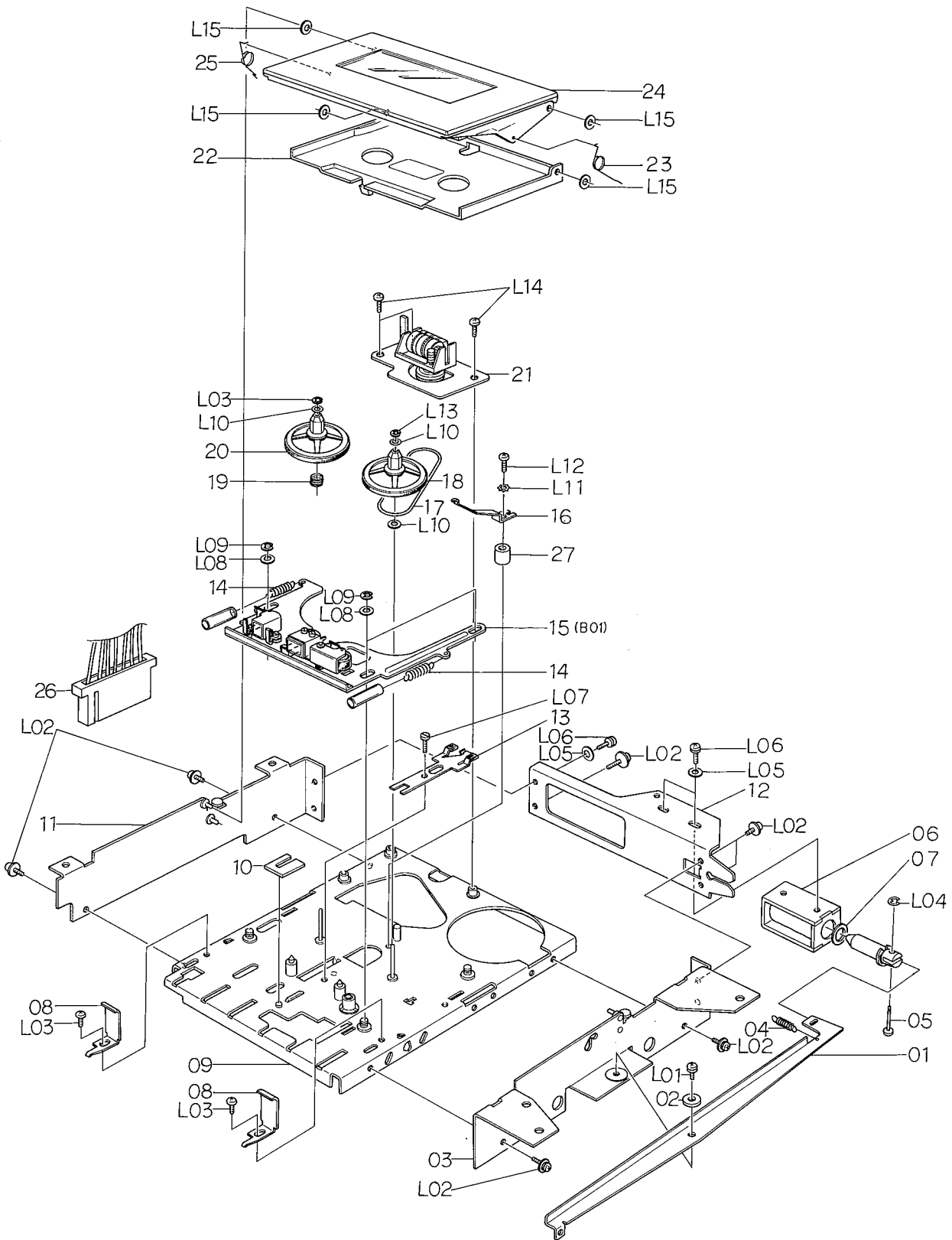

Fig. 9.6

Schematic Ref. No.	Part No.	Description	Q'ty
<b>A05-2</b>	<b>CA03294A</b>	<b>Mechanism Ass'y 350</b>	<b>1</b>
01	0C03954A	Solenoid Arm	1
02	0C03955A	Solenoid Arm Center	1
03	CA03290A	Mechanism Bracket R Ass'y	1
04	0C03957A	Solenoid Arm Spring	1
05	0C03906A	Solenoid Pin	1
06	0B08092A	Solenoid	1
07	0B08099A	Solenoid Mylar	1
08	0J03220A	Cassette Guide (C)	2
09	CA03292A	Mechanism Chassis Ass'y (D)	1
10	0C03863A	Head Base Spacer	1
11	CA03288A	Mechanism Bracket L Ass'y	1
12	0C03953A	Solenoid Holder	1
13	CA03140A	Brake Ass'y	1
14	0C03694B	Base Return Spring	2
15	CA03216A	Head Base (C) Ass'y	1
16	0C03852A	Cassette Well Spring (C)	1
17	0C03651A	Counter Belt (E)	1
18	CA03193A	Reed Hub Ass'y (Take-up)	1
19	0C03612A	Back Tension Spring	1
20	CA03192A	Reel Hub Ass'y (Supply)	1
21	BA03767A	Shut-off P.C.B. Ass'y	1
22	CA03243A	Cassette Well Ass'y	1
23	0C03760D	Lid Spring R	1
24	CA03283A	Cassette Lid Ass'y	1
25	0C03759D	Lid Spring L	1
26	0B08217A	7P Mini-Connector Plug	1
27	0C03706A	Well Spring Stud	1
L01	0E00510A	Screw M3x8 Philips Pan Head (2A)	1
L02	0E00606A	Screw M3x6 Philips Pan Head (3A)	7
L03	0E00226A	Screw M2.6x4 Philips Pan Head	2
L04	0E00222A	E Ring 2 mm	1
L05	0E00030A	Washer 3 mm Steel	3
L06	0E00622A	Screw M3x5 Philips Pan Head (2A)	3
L07	0E00166A	Screw M2x4 Cylinder Head	1
L08	0C06243A	W4-8-0.2F	3
L09	0E00181A	E Ring 3 mm	3
L10	0C03613A	Washer 1.6 mm Plaslics	3
L11	0E00233A	Washer 2.6 mm Toothed Lock Head (FT)	1
L12	0E00231A	Screw M2.6x8 Philips Pan Head (FT)	1
L13	0E00165A	E Ring 1.2 mm	2
L14	0E00219A	Screw M2.6x5 Philips Pan Head	3
L15	0E00254A	Washer 3.1 mm Plaslics	4

9.6. Head Base (C) Ass'y (B01)

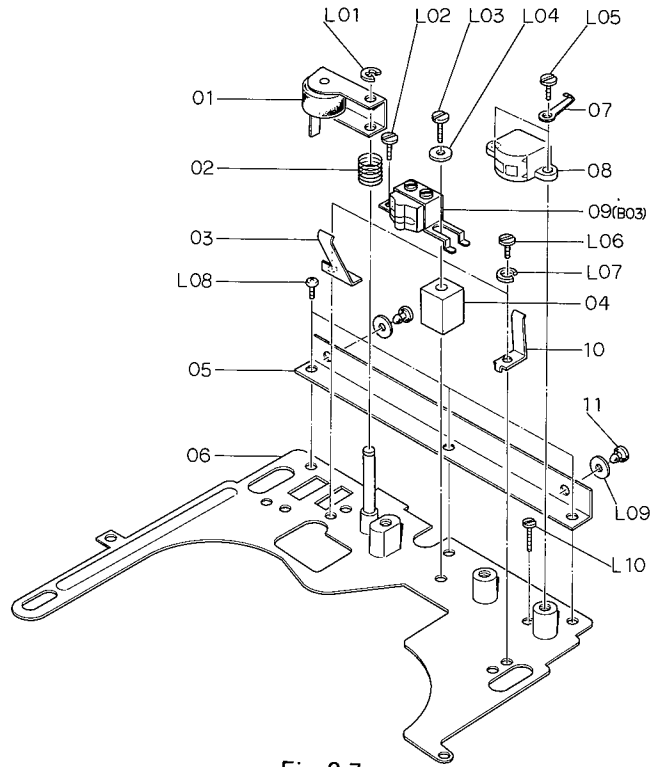

Fig. 9.7

Schematic Ref. No.	Part No.	Description	Q'ty
<b>B01</b>	<b>CA03216A</b>	<b>Head Base (C) Ass'y</b>	<b>1</b>
01	CA03159B	Pressure Roller (B) Ass'y	1
02	0C03758B	Pressure Roller Spring (B)	1
03	0C03691A	Cassette Retainer Spring R	1
04	0C03588A	Azimuth Adjust Rubber	1
05	0C03692D	Base Angle	1
06	CA03217A	Head Base (C) Sub Ass'y	1
07	0C03591A	Cord Holder	2
08	0C03862A	Erase Head	1
09	CA03201B	Record/Playback Head Ass'y	1
10	0C03690A	Cassette Retainer Spring L	1
11	0C03767A	Base Stopper Rubber	2
L01	0E00042A	E Ring 1.5 mm	1
L02	0E00166A	Screw M2x4 Cylinder Head	1
L03	0E00218A	Screw M2x10 Cylinder Head	1
L04	0E00149A	Washer 2.3 mm	1
L05	0E00185A	Screw M2x6 Cylinder Head	2
L06	0E00002A	Screw M2x3 Cylinder Head	2
L07	0E00025A	Washer 2 mm Spring	2
L08	0E00120A	Screw M2.6x3 Philips Pan Head	3
L09	0E00030A	Washer 3 mm Steel	2
L10	0E00218A	Screw M2x10 Cylinder Head	1

10. ACCESSORIES

9.7. MHX Motor Ass'y (B02)

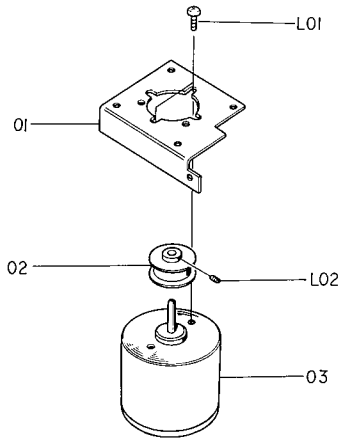

Fig. 9.8

9.8. Playback Head Ass'y (B03)

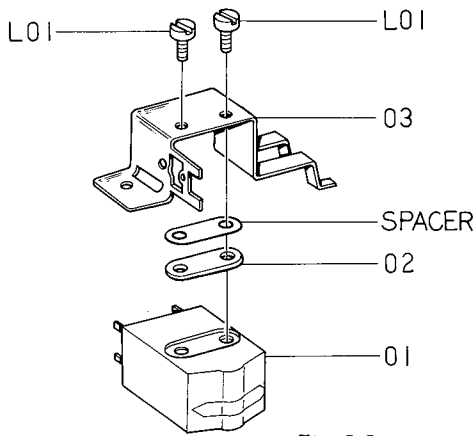

Fig. 9.9

10.1. AC Power Pack

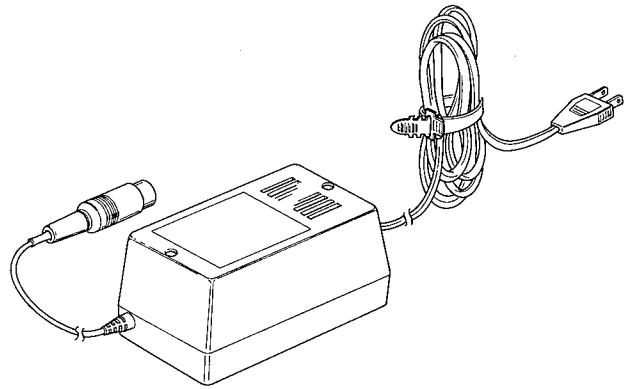

Fig. 10.1

Schematic Ref. No.	Part No.	Description	Q'ty
		<b>AC Power Pack</b>	
	0D03329U	AD-550U (120V)	
	0D03176B	AD-550E (220V)	
	0D03177B	AD-550B (240V)	

Schematic Ref. No.	Part No.	Description	Q'ty
<b>B02</b>	<b>CA03253B</b>	<b>MHX Motor Ass'y</b>	<b>1</b>
01	0J03221A	Motor Bracket C	1
02	0C03770A	Motor Pulley JA	1
03	0C03950A	MHX Motor (B)	1
L01	0E00120A	Screw M2x3 Philips Pan Head	2
L02	0E00224A	Screw M2x3 Cone Point	1
<b>B03</b>	<b>CA03207B</b>	<b>Record/Playback Head Ass'y</b>	<b>1</b>
01	GA02009L	RP-52 Record/Playback Head	1
02	OG01100B	Head Hold Spacer	1
03	OG01099C	Head Holder (B)	1
L01	0E00002A	Screw M2x3 Cylinder Head	2
		<b>Spacer</b>	
	AH01115A	PH Spacer t = 0.1 mm	
	AH01116A	PH Spacer t = 0.15 mm	
	AH01117A	PH Spacer t = 0.2 mm	
	AH01118A	PH Spacer t = 0.25 mm	
	AH01119A	PH Spacer t = 0.3 mm	

10.2. Holder Ass'y

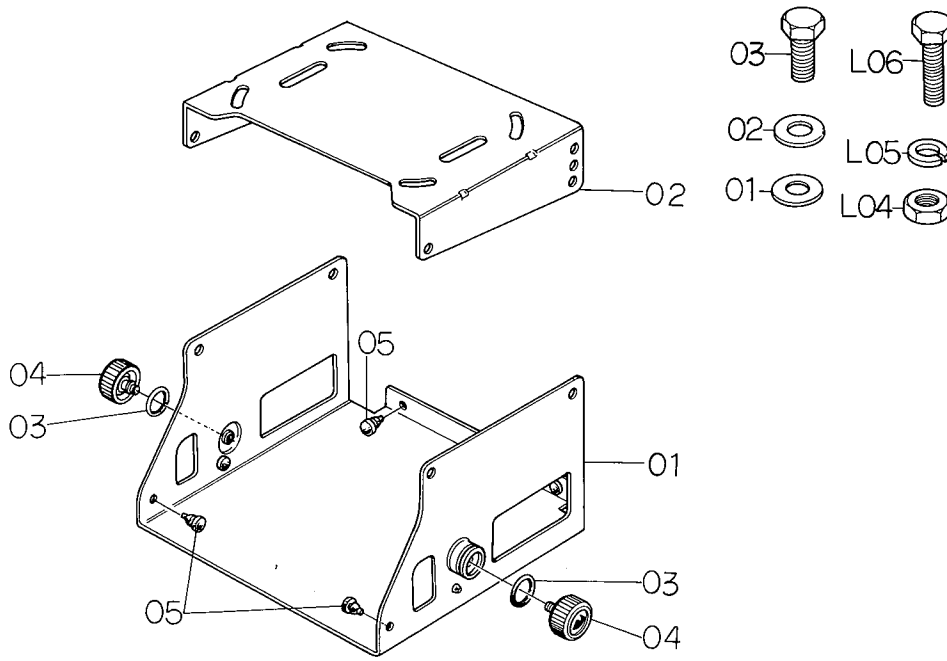

Fig. 10.2

10.3. ADS Cord Ass'y

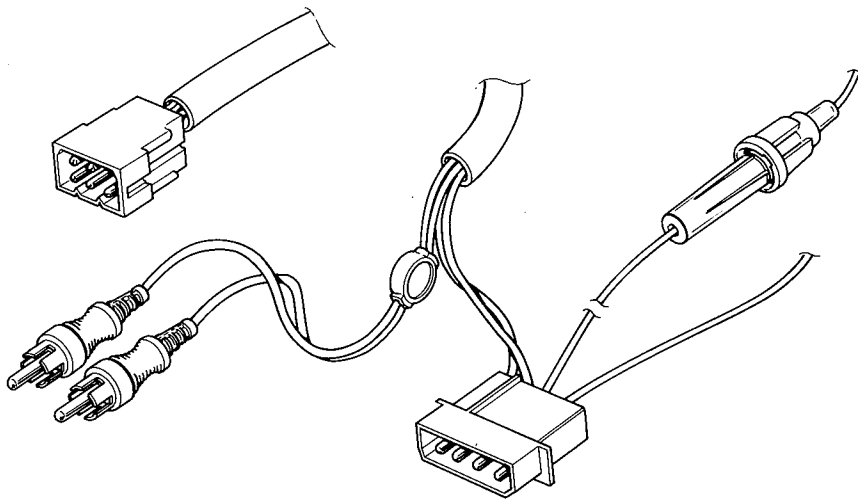

Fig. 10.3

Schematic Ref. No.	Part No.	Description	Q'ty	Schematic Ref. No.	Part No.	Description	Q'ty
	<b>DA03187A</b>	<b>Holder Ass'y</b>	1	L03	0E00706A	Bolt Hex M5x10	4
01	DA03185A	Holder Sub Ass'y	1	L04	0E00708A	Nut Hex M5	10
02	0D03290A	Hanger	1	L05	0E00709A	Washer 5mm Spring	12
03	0D03295A	Gum Ring	2	L06	0E00707A	Bolt Hex M5x16	6
04	DA03186A	Holder Knob Ass'y	2		<b>DA03196A</b>	<b>ADS Cord Ass'y</b>	1
05	0C03767A	Base Stopper	6			(NOTE: 0B08213U Fuse 6A)	
L01	0E00711A	Washer 5mm Plastics	8				
L02	0E00710A	Washer 5mm	12				

11. BLOCK DIAGRAM

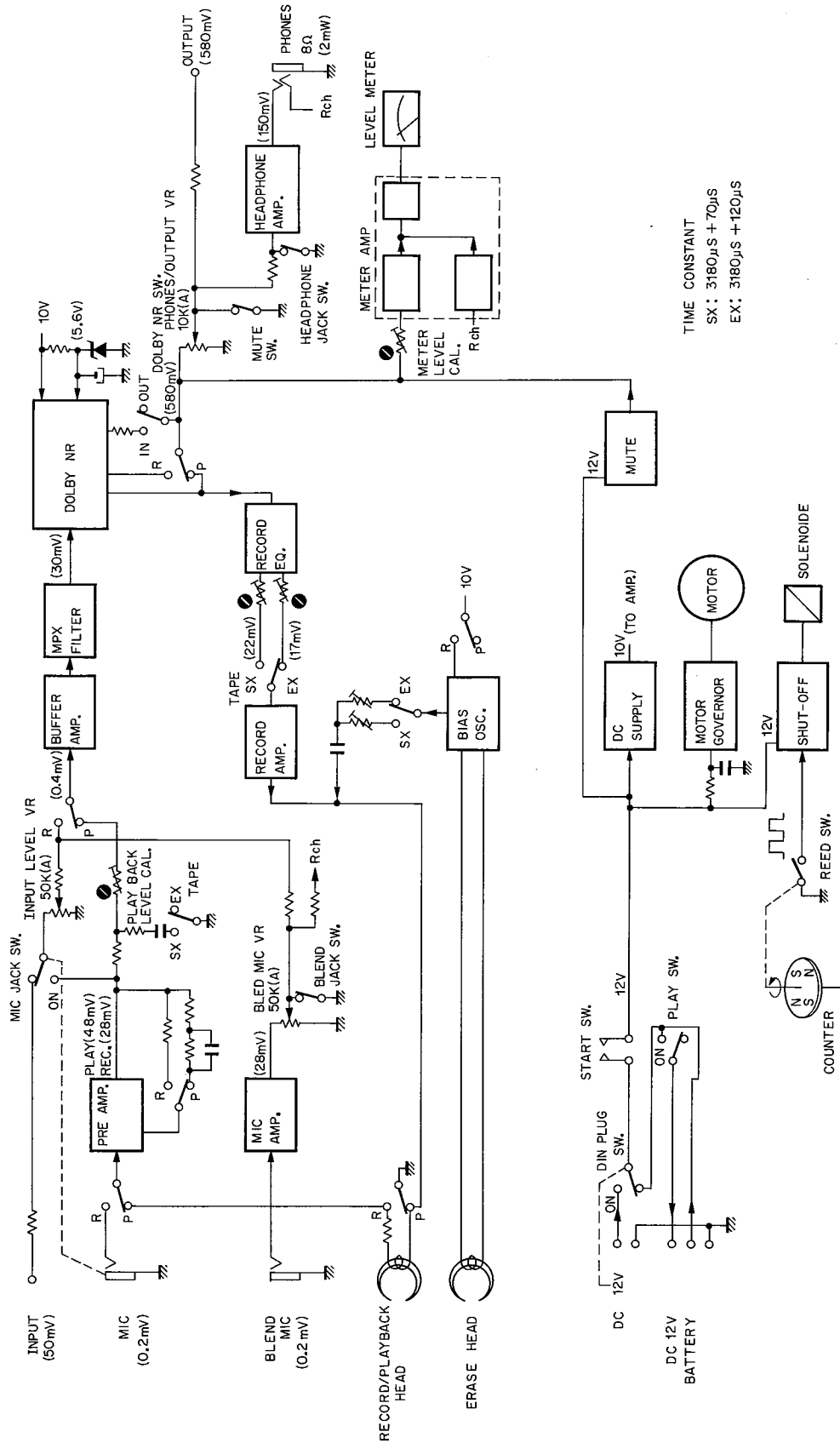

Fig. 11



## 12.2. Mechanism

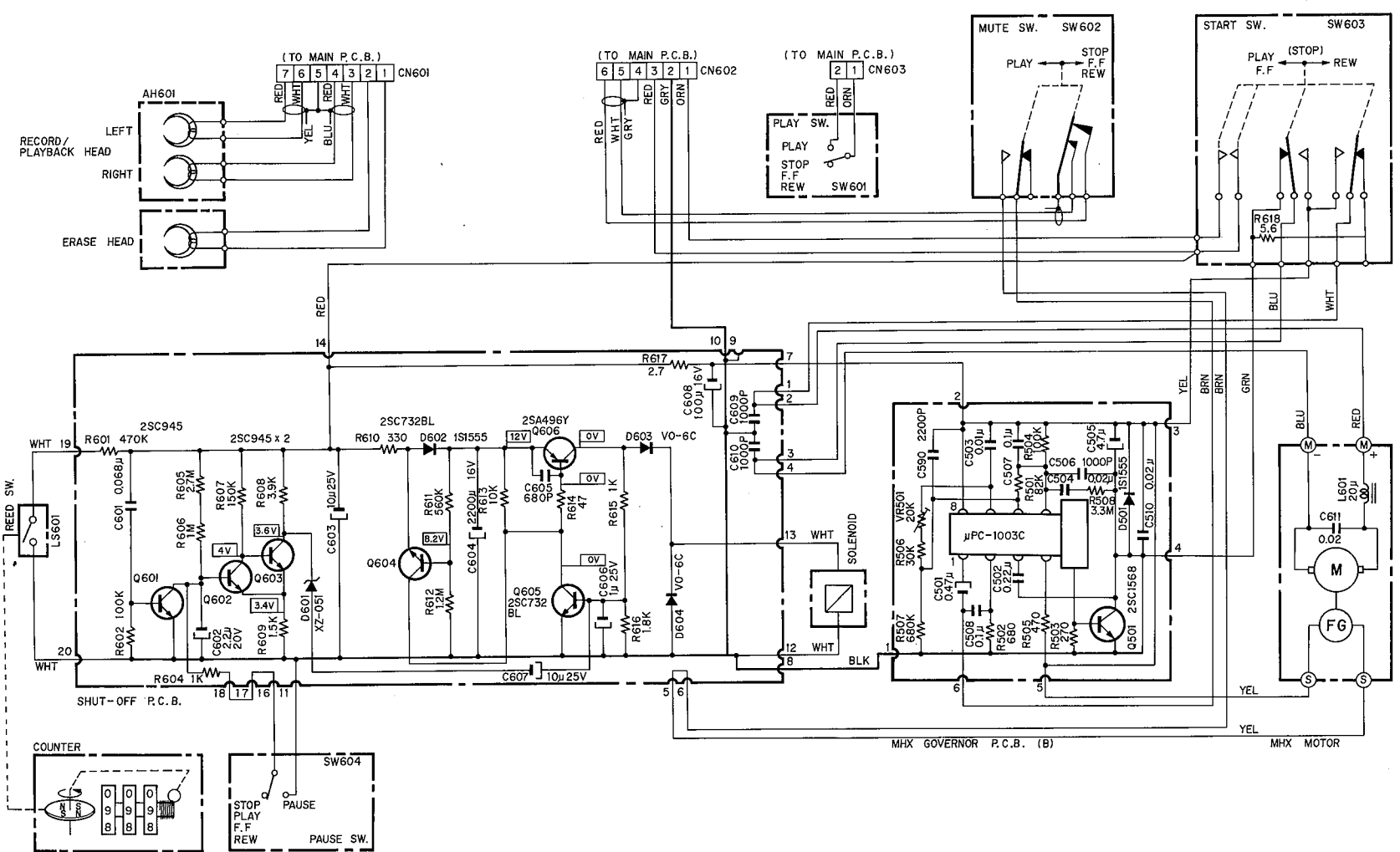

Fig. 12.2

## 13. SPECIFICATIONS

Power Supply	12 V DC (AC with AC Power Pack)
Power Consumption	40 W
Tape Speed	1-7/8 inches per second 4.8 centimeters per second
Wow & Flutter	Less than 0.13% (DIN 45507 Wtd Peak) Less than 0.08% (Wrms)
Frequency Response	40 - 15,000 Hz $\pm$ 3 dB (SX, EX11 tapes, with or w/o Dolby)
Signal-to-Noise Ratio	Better than 58 dB (@ 400 Hz, 3% Distortion, CCITT, Wrms, SX tape)
Total Harmonic Distortion	Less than 2% (@ 400 Hz, 0 dB)
Erase	Better than 60 dB (@ 1 kHz saturation level)
Channel Separation	Better than 35 dB (@ 1 kHz, 0 dB)
Crosstalk	Better than 60 dB (@ 1 kHz, 0 dB)
Bias Frequency	105 kHz
Input Sensitivity/Impedance	
Mic	0.2 mV/600 ohms
Blend Mic	0.2 mV/600 ohms
Line	50 mV/50 kohms
Output Level	
Line	580 mV (0 dB)
Headphone	2 mW into 8 ohms (0 dB)
Dimensions	7-1/3"(W) x 3-1/2"(H) x 9-1/2"(D) inches 186(W) x 90(H) x 242(D) mm
Weight	6.6 lbs. (3 kg)

• Specifications and appearance design are subject to change for further improvement without notice.

• Dolby NR under license from Dolby Laboratories Inc.

• The word "DOLBY NR" and the Double-D-Symbol are trademarks of Dolby Laboratories Inc.

## 14. TROUBLE SHOOTING

- 14.1. Note**
- (1) Check to insure whether the output 10V (approximately) of the power supply is correct.
  - (2) Either Nakamichi SX or EX 11 tape shall be used while adjustment (particularly while adjustments of bias and record/playback level).  
Should another different branded tape be used in its place, the machine shall previously be adjusted according to each of the actual tapes in use.  
However, if a low quality tape should be used, optimum quality of machine will not be obtained (such as Distortion, Signal to Noise Ratio, Dynamic Range, etc. will be deteriorated).
  - (3) Depress the pause button during Play or Fast-forward. The tape could be stopped but the motor is still rotating.  
Depress the pause button during rewind, and this time the motor and tape are always in rewind mode (the tape keeps rotating).
  - (4) When Flywheel is replaced, clean the Capstan before start of the operation (with alcohol-dipped cloth).
- 14.2. Trouble Shooting**
- 14.2.1. Motor does not rotate:**
- (1) Defective Motor.
  - (2) Defective Motor Governor.
  - (3) Defective Start Switch Ass'y.
  - (4) Defective Mute Switch Ass'y.
  - (5) Wire between Motor and Motor Governor is cut.
  - (6) Wire between Motor Governor and Start Switch Ass'y is cut, etc.
  - (7) 12V is not being supplied to the Motor Governor.



**14.2.2. No power transmission:**

- (1) Defective Power Connectors.
- (2) Defective Power Switch (inside of Mechanism).
- (3) Defective D.C. Supply block.

**14.2.3. Sound is distorted:**

- (1) Incorrect adjustment of Bias against tape.
- (2) Record/Playback Head is dirty.
- (3) Defective cassette tape.
- (4) Record/Playback Head is magnetized.
- (5) Weak Bias oscillation or does not oscillate.
- (6) Defective Record/Playback Head.
- (7) Excessively high level at Record/Playback.

**14.2.4. High Frequency is deteriorated while playback:**

- (1) Incorrect adjustment of Record/Playback Head azimuth.
- (2) Record/Playback Head is dirty.
- (3) Record/Playback Head is magnetized.
- (4) Excessive Wow/Flutter.
- (5) Inaccurate tape travel.
- (6) Defective Record/Playback Head.

**14.2.5. High Frequency is deteriorated while record/playback:**

- (1) Incorrect adjustment of Bias against tape (excessive bias current to the record/playback head).
- (2) Defective cassette tape.
- (3) Defective Record/Playback Head.
- (4) Record/Playback Head is dirty.

**14.2.6. Does not playback:**

- (1) Record/Playback Head is dirty.
- (2) Record/Playback Head is defective (open circuit or short circuit).
- (3) Defective Playback Amplifier.
- (4) Mute is not released.
- (5) Defective Mute Switch.
- (6) Defective Dolby N.R. Circuit.
- (7) Defective Output Buffer Amplifier.
- (8) Defective Record Switch.
- (9) Defective Output Jack.
- (10) Wire between Record/Playback Head and Playback Amplifier is cut.
- (11) Inaccurate tape travel.
- (12) Defective Output Jack.

**14.2.7. Does not record:**

- (1) Defective Bias Circuit.
- (2) Defective Erase Head (open circuit or short circuit).
- (3) Defective Record/Playback Head (open circuit or short circuit).
- (4) Record/Playback Head is dirty.
- (5) Defective Dolby N.R. Circuit.
- (6) Mute is not released.
- (7) Defective Record Amplifier.
- (8) Defective Record Switch.
- (9) Defective Record Link Ass'y.
- (10) Wire between Record/Playback Head and Record Amplifier is cut.
- (11) Defective Input Amplifier and/or Input Jack.
- (12) Inaccurate tape travel.

**14.2.8. Excessive Wow/Flutter:**

- (1) Defective Flywheel Ass'y.
- (2) Defective Motor.
- (3) Defective Motor Governor.
- (4) Defective Drive Belt.
- (5) Defective Pressure Roller Ass'y.
- (6) Defective Idler Pulley Ass'y.
- (7) Slippage between Pressure Roller and tape.
- (8) No clearance between Flywheel Ass'y and Flywheel Holder Ass'y.
- (9) Defective Cassette Tape (hard to rotate).
- (10) Defective Tape Counter (hard to rotate or sticky, etc.).
- (11) Excessive Back-tension.
- (12) Irregular Take-up Torque.

**14.2.9. Does not erase or incomplete erasure:**

- (1) Erase Head is dirty.
- (2) Defective Erase Head (open circuit or short circuit).
- (3) Inaccurate tape travel.
- (4) Weak Bias oscillation or does not oscillate.
- (5) Excessively high frequency of Bias oscillator.
- (6) Wire between Erase Head and Bias oscillator is cut.

**14.2.10. Auto Shut-off does not work at end of tape:**

- (1) Defective Auto Shut-off Detector.
- (2) Defective Auto Shut-off Driver.
- (3) Defective Solenoid Driver.
- (4) Defective Deck Button (hard to operate).
- (5) Wire between Solenoid and Driver is cut.
- (6) Incorrect adjustment of Solenoid.

**14.2.11. Auto Shut-off activates at position other than tape end:**

- (1) Defective Auto Shut-off Detector.
- (2) Defective Auto Shut-off Driver.
- (3) Defective Solenoid Driver.
- (4) Defective Counter.
- (5) Defective Counter Belt.
- (6) Defective Cassette Tape (hard to rotate).

**14.2.12. Meter does not flutter:**

- (1) Defective Meter (open circuit or short circuit).
- (2) Defective Meter Circuit.
- (3) Wire between Meter and Meter Circuit is cut.
- (4) Tape does not playback (playback mode).
- (5) Meter lead is shorted.
- (6) Defective Input Amplifier.

**14.2.13. Defective tape travel:**

- (1) Record/Playback Head is misaligned against Capstan.
- (2) Pressure Roller is misaligned against Capstan.
- (3) Excessive Take-up Torque.
- (4) Pressure of Pressure Roller is weak.
- (5) Erase Head is misaligned against Capstan.
- (6) Defective Capstan (bent, etc.).
- (7) Defective Capstan Flange (bent, etc.).
- (8) Reference Pin is bent.
- (9) Head Base is bent.
- (10) Incorrect adjustment of Record/Playback Head position.
- (11) Defective Erase Head.
- (12) Defective Pressure Roller.

**14.2.14. Tape does not rotate:**

- (1) Defective Motor.
- (2) Defective Motor Governor.
- (3) Defective Drive Belt.
- (4) Drive Belt is out of place.
- (5) Defective Reel Hub.
- (6) Defective cassette tape (hard to rotate).
- (7) Incorrect loading of cassette tape.
- (8) Pressure Roller is not in contact with Capstan.
- (9) Defective Power Connectors.

**14.2.15. Drive Belt is out of place:**

- (1) Motor is misaligned.
- (2) Idler Pulley Ass'y is misaligned.
- (3) Excessive clearance between Flywheel Ass'y and Flywheel Holder Ass'y.
- (4) Defective Drive Belt.

**14.2.16. Signal to Noise Ratio is deteriorated:**

- (1) Record/Playback Head is magnetized.
- (2) Excessive Bias Leakage.
- (3) Record/Playback Head is dirty.
- (4) Defective Record/Playback Head.
- (5) Defective cassette tape.
- (6) Defective D.C. Supply block (excessive ripple).
- (7) Defective Input Amplifier (noise is great).
- (8) Defective Output Amplifier (noise is great).
- (9) Incorrect adjustment of hum balance wire.

**14.2.17. Channel separation is deteriorated:**

- (1) Incorrect tape travel.
- (2) Defective Record/Playback Head.

**14.2.18. Tape speed is too fast or slow:**

- (1) Defective Motor.
- (2) Defective Motor Governor.
- (3) Pressure Roller is not in contact with Capstan.
- (4) Defective Mute Switch (contacting chassis).
- (5) Defective cassette tape (hard to rotate).

**14.2.19. Does not Eject:**

- (1) Defective Eject Linkage Arm.
- (2) Defective Stop/Eject Button.
- (3) Eject Linkage Arm is out of place.
- (4) Defective cassette tape.

**14.2.20. Level variations:**

- (1) Incorrect tape travel.
- (2) Record/Playback Head is dirty.
- (3) Defective Record/Playback Head.
- (4) Record/Playback Head is misaligned.
- (5) Defective cassette tape.
- (6) Incorrect adjustment of Head Base stroke.

**14.2.21. Bias does not oscillate:**

- (1) No voltage to Bias oscillation circuit.
- (2) Defective Bias oscillation circuit.
- (3) Defective Erase Head (open circuit or short circuit).

**14.3. Check method when parts are replaced.**

When any part/part ass'y of the Nakamichi 350 is replaced with new one, please check to insure the following.

**14.3.1. When Motor is replaced:**

- (1) Tape speed.
- (2) Wow/Flutter.
- (3) Drive Belt position (out of place).

**14.3.2. When Drive Belt is replaced:**

- (1) Drive Belt position (out of place).
- (2) Tape speed.
- (3) Wow/Flutter.

**14.3.3. When Record/Playback Head is replaced:**

- (1) The inclination of a Record/Playback head.
- (2) Azimuth/Height.
- (3) Tape Travelling.
- (4) Playback output.
- (5) Playback frequency response.
- (6) Overall frequency response.
- (7) Distortion.
- (8) Signal to Noise Ratio.
- (9) Channel separation.

**14.3.4. When Erase Head is replaced:**

- (1) Tape travelling.
- (2) Azimuth/Height (record/playback head).
- (3) Bias frequency.
- (4) Erasure.
- (5) Overall frequency response.

**14.3.5. When Flywheel Ass'y is replaced:**

- (1) Clearance between Flywheel and Flywheel Holder.
- (2) Tape travelling.
- (3) Azimuth/Height.
- (4) Tape speed.

**14.3.6. When Pressure Roller is replaced:**

- (1) Tape travelling.
- (2) Azimuth/Height.
- (3) Tape speed.
- (4) Wow/Flutter.
- (5) Pressure Roller timing.

**14.3.7. When Tape Counter is replaced:**

- (1) Tape speed.
- (2) Wow/Flutter.
- (3) Memory rewind operation.
- (4) Counter check (sticky, etc.).
- (5) Auto shut-off operation.

**14.3.8. When Reel Hub Ass'y is replaced:**

- (1) Torque check (take-up, fastforward and/or rewind).
- (2) Tape speed.
- (3) Wow/Flutter.

**14.3.9. When Deck Button Ass'y is replaced:**

- (1) Button operation.
- (2) Head base stroke.
- (3) Pause switch operation.
- (4) Record switch operation.
- (5) Mute switch operation.
- (6) Start switch operation.

**14.3.10. When Idler Pulley Ass'y is replaced:**

- (1) Drive Belt position (out of place).
- (2) Tape speed.
- (3) Wow/Flutter.
- (4) Rewind time.
- (5) Fastforward time.
- (6) Brake Timing.

**14.3.11. When Motor Governor is replaced:**

- (1) Tape speed.
- (2) Wow/Flutter.

**14.3.12. When Level Meter is replaced:**

- (1) Meter level.
- (2) Meter check (sticky, etc.).

**14.3.13. When Solenoid is replaced:**

- (1) Solenoid position.

**14.3.14. When Record Link Ass'y is replaced:**

- (1) Record Link ass'y adjustment.

# Service Manual

# Nakamichi 350

## **NAKAMICHI RESEARCH INC.**

1-153 Suzukicho, Kodaira, Tokyo

Phone: (0423) 42-1111

Telex: 2832610 (NAKREI J)

Cable: NAKREI KKB

## **NAKAMICHI RESEARCH (U.S.A.) INC.**

West Coast Office

1101 Colorado Avenue,

Santa Monica, Calif. 90401

Phone: (213) 451-5901

Telex: 652429 (NAKREI SNM)

## **NAKAMICHI RESEARCH (U.S.A.) INC.**

New York Office

220 Westbury Avenue,

Carle Place, N.Y. 11514

Phone: (516) 333-5440

Telex: 144513 (NAKREI CAPL)